

> Structural Glass Façades

Structural Glass

Storefront & Façade Systems

CARVART delivers advanced storefront façade systems that combine structural glass performance with architectural precision. Through multiple engineered approaches—including custom point fittings, structural glass fins, top-hung support hardware, and specialized base-mount assemblies—we tailor each solution to achieve the desired aesthetic while maintaining structural integrity. Our focus on prefabricated, unitized assemblies ensures controlled fabrication, accelerated installation, and seamless integration into the building envelope, providing both visual impact and dependable performance.







Capabilities

Structural Glass

- Point-Supported Glazing
- Structural Glass Fins
- Structural Silicone Glazing (SSG)
- Top-Hung Glass Systems
- Base-Supported Glass Systems
- Cable Net / Tension Systems
- Hybrid Structural Glass Systems

System Example

Base-Supported + Fins

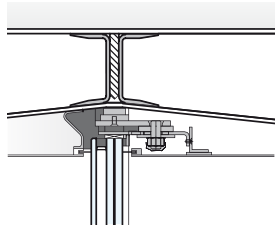

Connection at Top

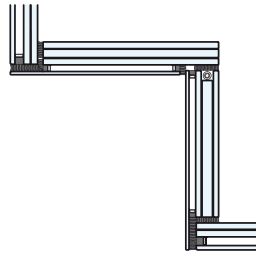

Corner

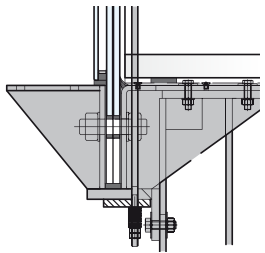

Connection at Base

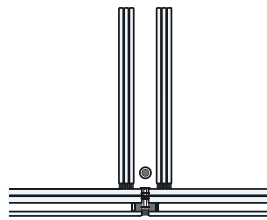

Vertical Glass Joint





Glass Point Fixing



Frameless

Flush Mounting Systems

CARVART's unique pre-glazed structural systems were designed to be dynamic given as-built and site conditions where achieving a frameless look might seem impossible.

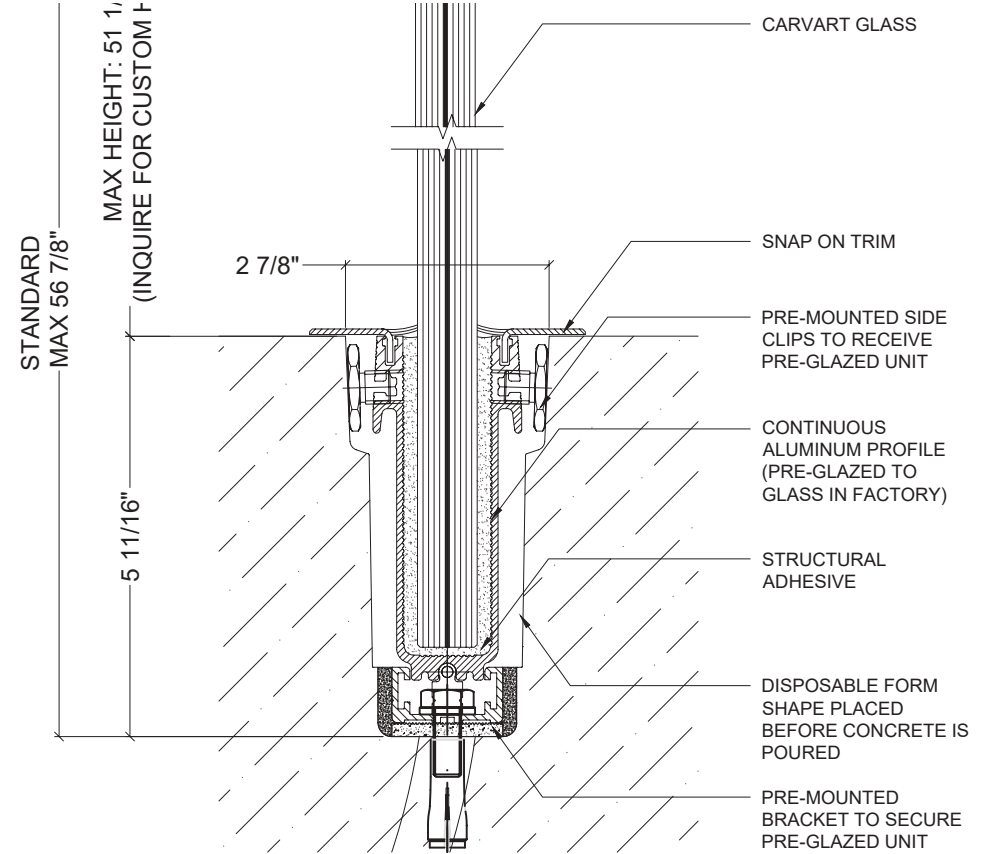

Pre-Fabrication Module Systems

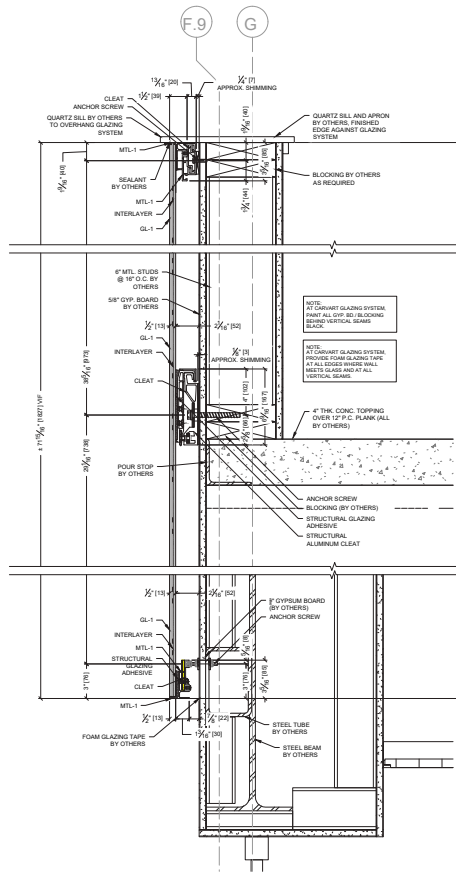

2 VERTICAL SECTION DETAIL
SCALE: 3" = 1'-0"



Mullion Systems

Storefront & Façade Systems

CARVART delivers advanced adaptations of glass façade systems that merge structural performance with architectural refinement. Designed around distinctive mullion profiles and custom-finished aluminum extrusions, our systems allow for tailored sightlines, depth variations, and refined detailing to support each project's design intent. Through engineered framing solutions, reinforced verticals, and precision-integrated glazing assemblies, we achieve both aesthetic clarity and structural reliability. A wide range of premium finishes—including anodized, powder coat, PVD, and specialty metal looks—ensures each installation integrates seamlessly with the broader architectural vision while maintaining durability and long-term performance.





Gallery

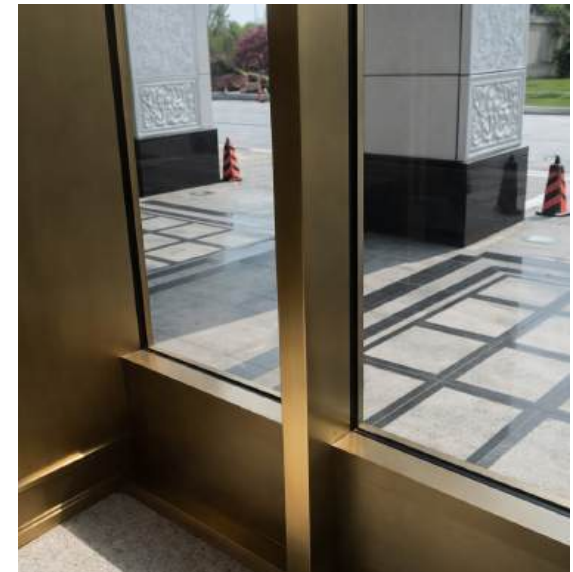

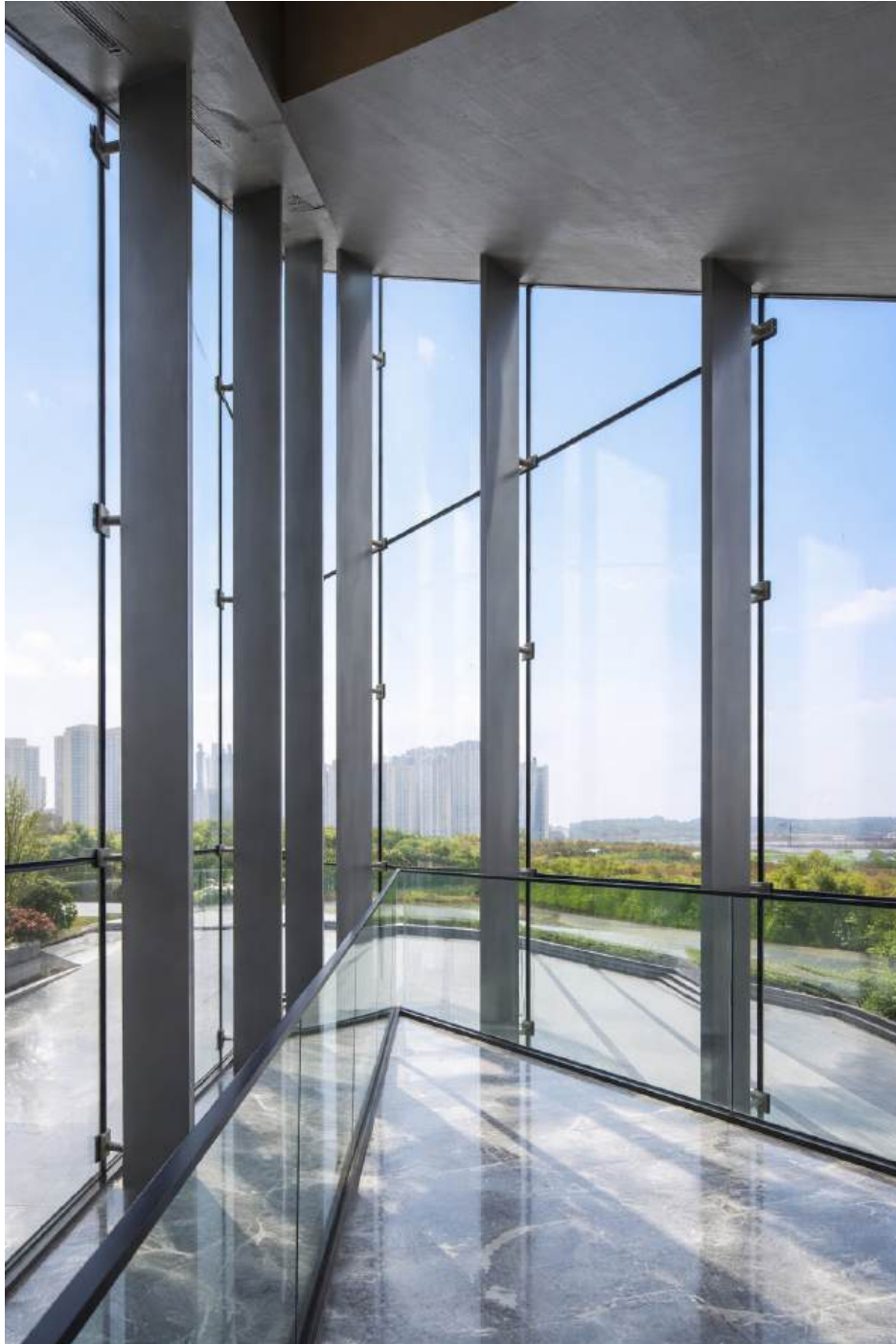





CARVART®