

glassSTACKWALL > Frameless

GW-STAK-XF

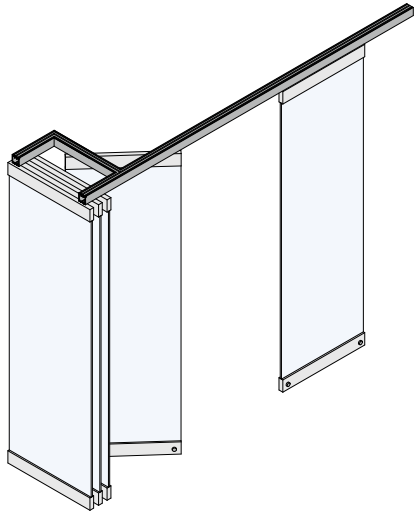

3D ISOMETRIC VIEW

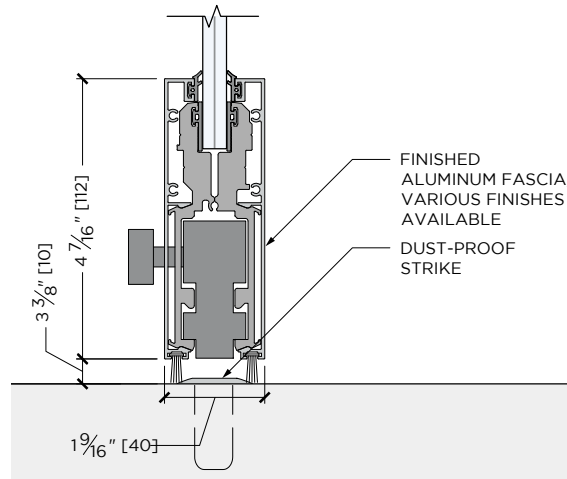

TYPICAL DETAILS



Specifications

glassSTACKWALL > Frameless

Top-hung glass panels that are captured by top and bottom rails and travel individually along a suspended track and stack and store into a designated parking area. Top tracks can be concealed into the ceiling for minimal look with the advantage of glass panels completely disappear from the opening or be left exposed.

APPLICATIONS —

Space dividers, offices, commercial spaces, conference rooms

HARDWARE —

Anodized aluminum finishes; glass held by steel clamps; top-hung panels that slide through track and individually stack into parking area

HARDWARE FINISHES —

- MFSA (satin anodized aluminum)
- MFPA (polished anodized aluminum)
- MFBA (black anodized aluminum)
- MFBN (brushed antique nickel)
- MFBN (brushed satin nickel)

PANEL WIDTH (OVERALL MAXIMUM) —

Maximum: 47"

SYSTEM HEIGHT (OVERALL MAXIMUM) —

Maximum Height: 120"

MOUNTING OPTIONS —

- Top-hung; header must support full weight of system
- Glass held by clamps in panel shoe

GLASS THICKNESS —

Tempered monolithic and tempered laminated:
-3/8" [6mm] - 13/16" [21mm]

WARRANTY —

1 Year Limited Warranty

Specification Code: **GS-STAK-XF**

GW	STAK	XF
LINE	TYPE	MODEL/ID