

glassFOLDWALL > Frameless

GW-FOLD-XF

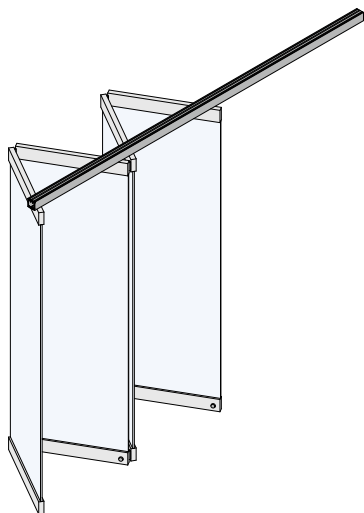

3D ISOMETRIC VIEW

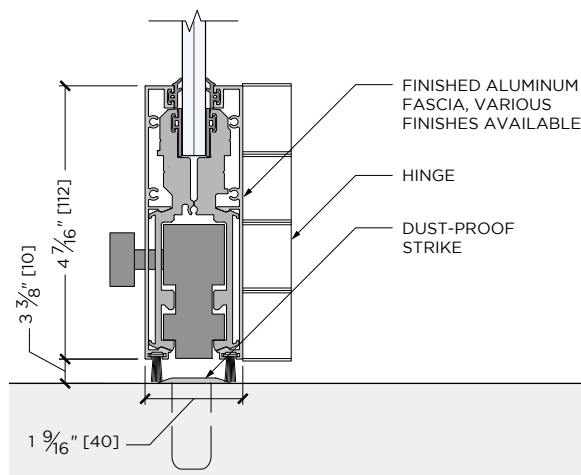

TYPICAL DETAILS



Specifications

glassFOLDWALL > Frameless

Folding frameless walls are easy-to-operate privacy options where glass panels are connected via hinges that move the entire series as they are pulled along the top track. Glass panels have polished, exposed vertical edges and are captured by top and bottom rails. The track of top-hung system can be concealed in the ceiling. Vertical profiles are available at the walls to further improve acoustic isolation. This system offers users a clean, refined frameless look for every space.

APPLICATIONS —

Space dividers, offices, commercial spaces, conference rooms

HARDWARE —

Anodized aluminum finishes; glass held by steel clamps; top-hung panels fold with hinges

HARDWARE FINISHES —

- MFSA (satin anodized aluminum)
- MFPA (polished anodized aluminum)
- MFBA (black anodized aluminum)
- MFBN (brushed antique nickel)
- MFBN (brushed satin nickel)

PANEL WIDTH (OVERALL MAXIMUM) —

Maximum: 37"

SYSTEM HEIGHT (OVERALL MAXIMUM) —

Maximum Height: 120"

MOUNTING OPTIONS —

- Top-hung; load-bearing header required
- Glass held by clamps in panel shoe

GLASS THICKNESS —

Tempered monolithic and tempered laminated:
-3/8" [6mm] - 13/16" [21mm]

WARRANTY —

1 Year Limited Warranty

Specification Code: **GW-FOLD-XF**

GW	FOLD	XF
LINE	TYPE	MODEL/ID