

CARVART®

# MANUAL OF INSTALLATION USE and MAINTENANCE

AURA ZIP  
(off-axis)

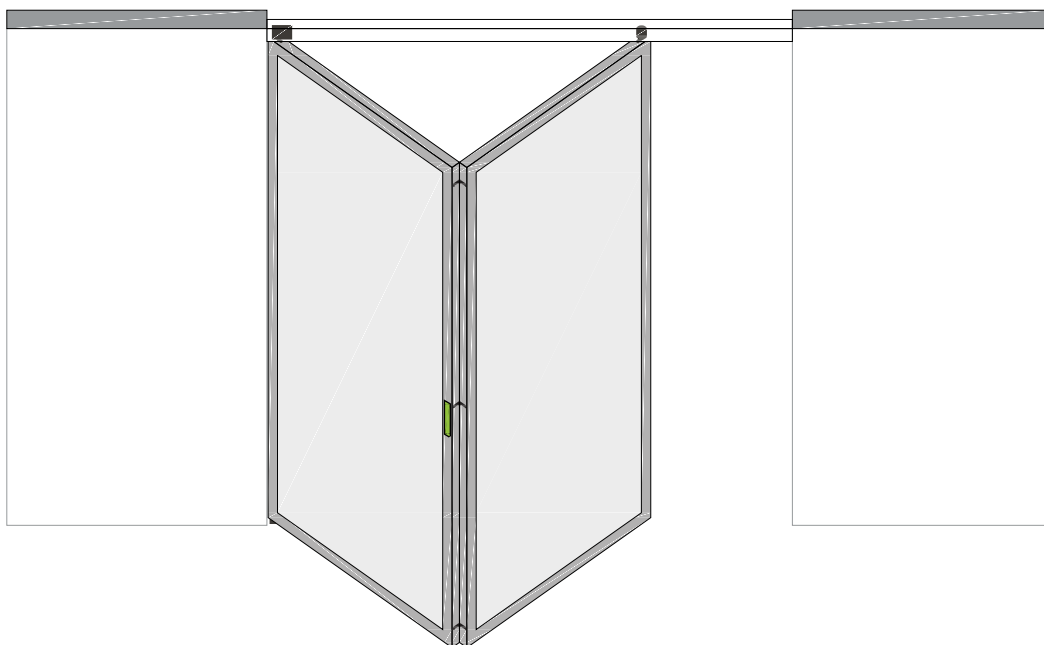

## TOOLS NEEDED FOR ASSEMBLY

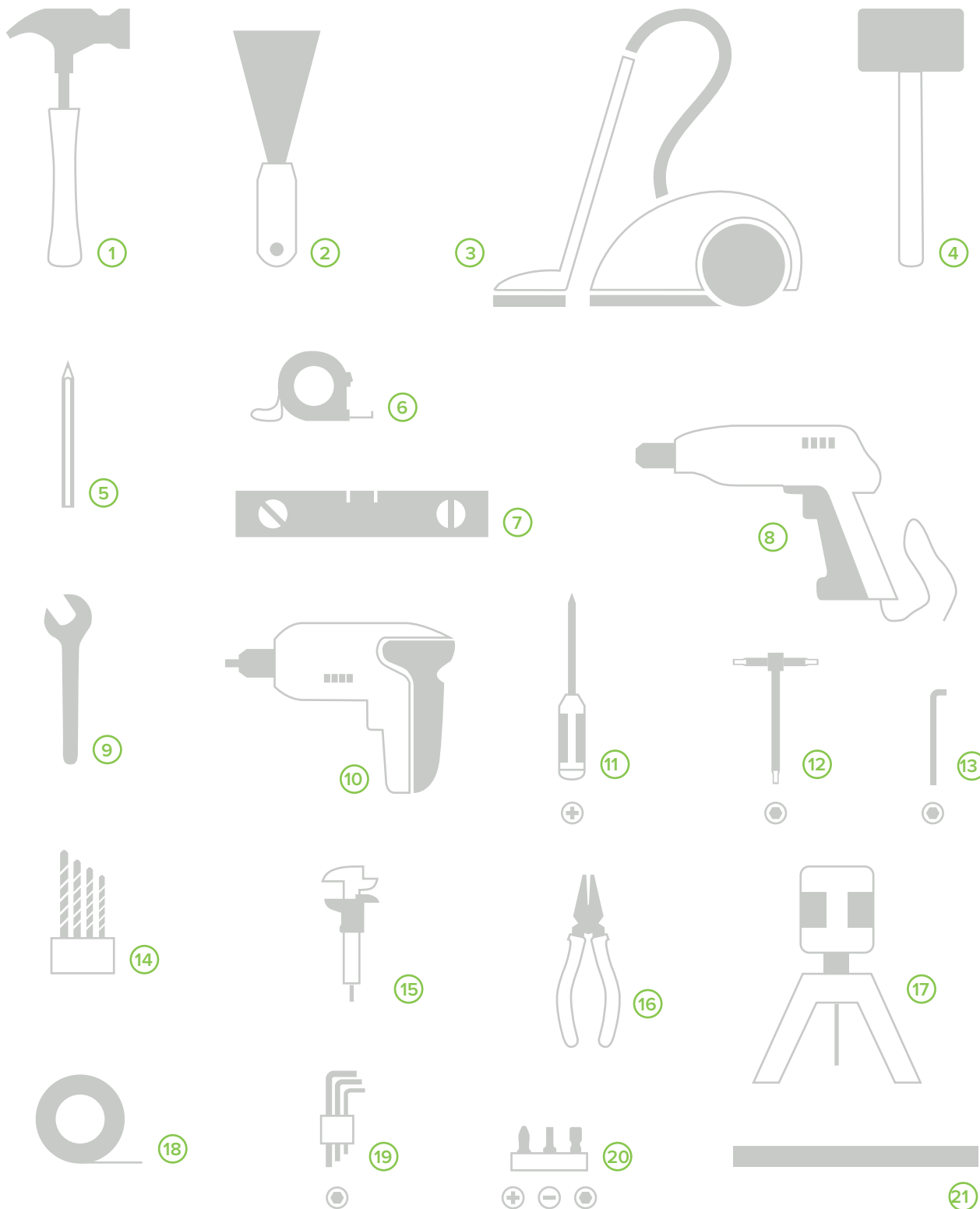

1. Hammer
2. Spatula
3. Vacuum cleaner
4. Hard rubber hammer
5. Pencil
6. 5-meter tape measure
7. Bubble level

8. Impact drill
9. Lowered fork wrench (ch 8 and 17)
10. Screwdriver
11. Phillips screwdriver
12. T-shaped hex wrench (ch 5)
13. Lowered hex wrench (ch 3)
14. Set of drill bits for drilling floor

15. Caliper
16. Universal caliper
17. Laser spirit level
18. Paper scotch
19. Hex wrench set
20. Set of screwdriver bits
21. MDF for hinges (L=110 cm)

## COMPONENT BOARD

COD. 400008 (burnished)  
COD. 400008.1 (niploy)

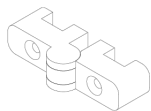

Aurea Zip hinge burnished  
black or niploy

COD. 01702.05030 (burnished)  
COD. 01702.5030I (inox)

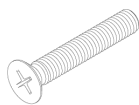

TPSEI screw M5x30mm  
burnished or stainless steel



VSTEl grain M4x25mm  
conical tip

COD. 009010.201



Hinge thickness  
6x12x0,1 mm

COD. 009010.202



Hinge thickness  
6x12x0,2 mm

COD. 400008C



Calibrated hinge pin Ø4x16

COD. 400013.2

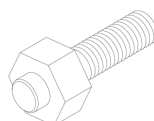

Floor pin Aurea Zip D=24xH=60  
black burnished

COD. 400015

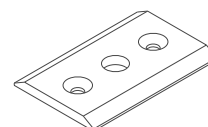

Chamfered floor plate  
62x54x4mm burnished

COD. 400014.01

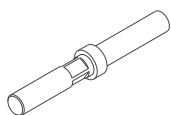

Upper hinge pin D=100mm  
black galv. for initial module

COD. 400023

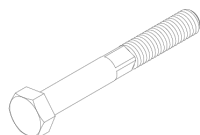

Bogie pin standard  
module 41 mm

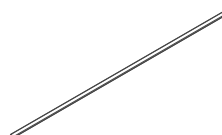

Beveled threshold  
3130x54x4 mm

COD. 02503.10



Hex nut  
low M10

COD. 400012.1

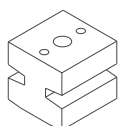

Upper pin retainer  
39x41x42mm PVC black

COD. 05106 (nera) COD.  
05106.1032 (nichel)

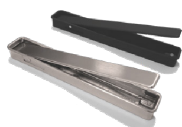

Recessed handle 75x32mm  
black or polished nickel finish

COD. 04202.0636

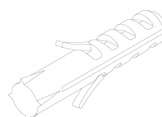

Plastic multi-purpose  
Zebra 6x35mm

COD. 01207.40045

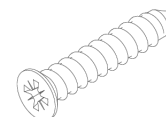

TPS screw 4x45mm  
galvanized

COD. 03801.04008



VSTEl grain M4x8mm  
conical tip DIN 914

COD. 03801.06050

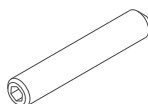

ISO4027 grain 45H (GR) EI3  
M6x50mm conical tips

COD. 163024

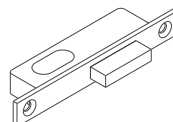

Lock for  
sliding doors

COD. 163043



Cylinder for lock

COD. 440000

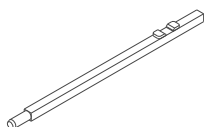

Ground pivot  
L=900 mm

COD. 164010.02



Trolley Ø40mm

COD. 03101.2910



Notched outer washer  
D=10.5mm (grower)

### INITIAL CHECK

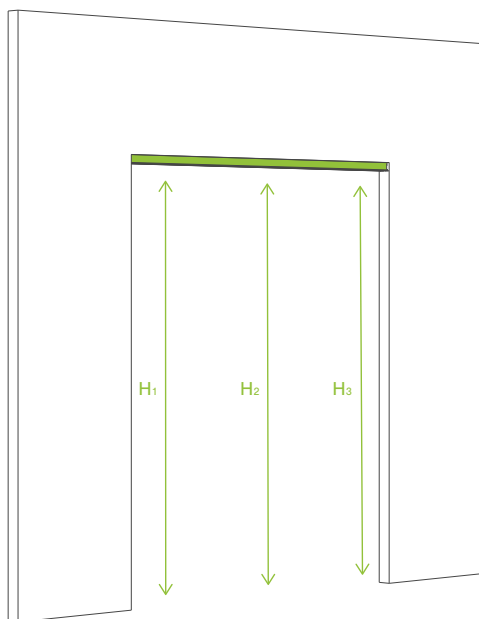

Measure height/width of the opening and check that correspond with the design dimensions.

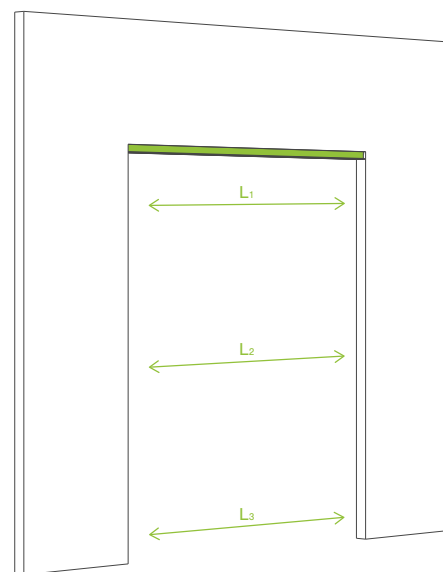

### OUT-OF-LEAD CONTROL

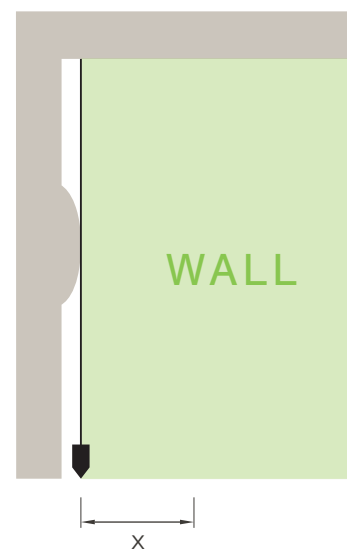
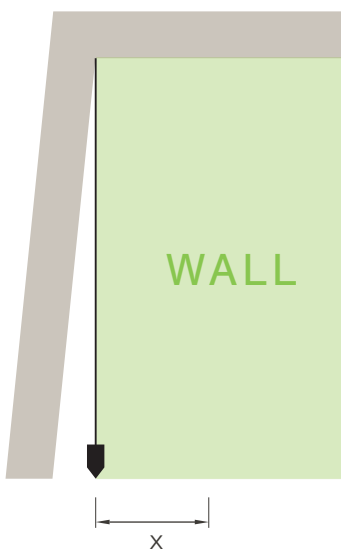
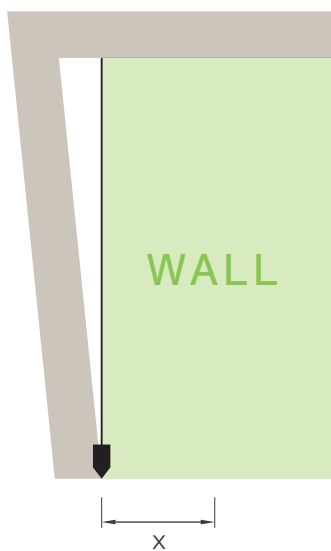
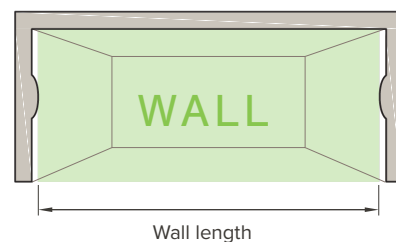
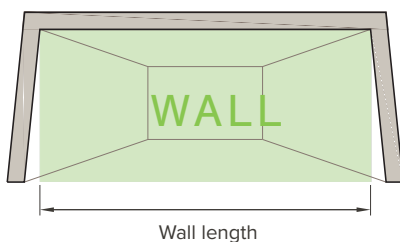
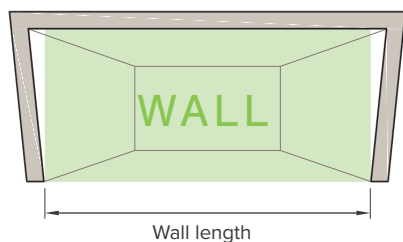

X = distance of the floor plate from the lead (SEE PAGE 7)

## TYPE OF MODULES

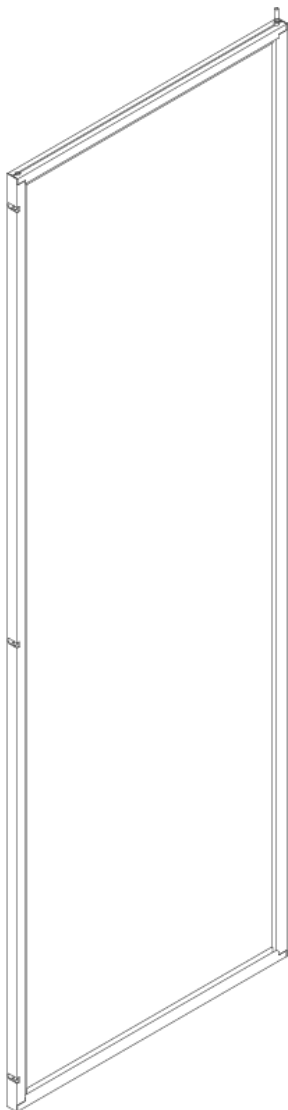

### INITIAL MODULE

Ground and top pivot module, hinge slots on one side only.

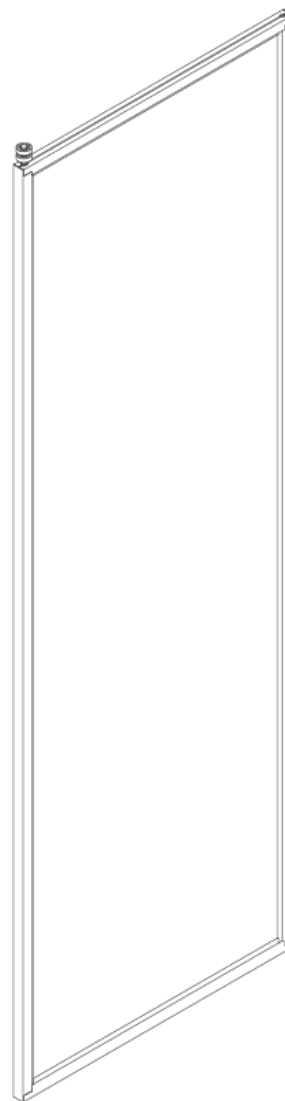

### FINAL MODULE

Module with upper carriage, hinge slots only on the side opposite the carriage.

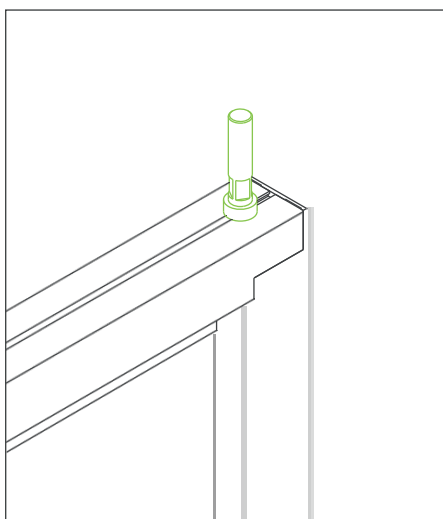

TOP PIN

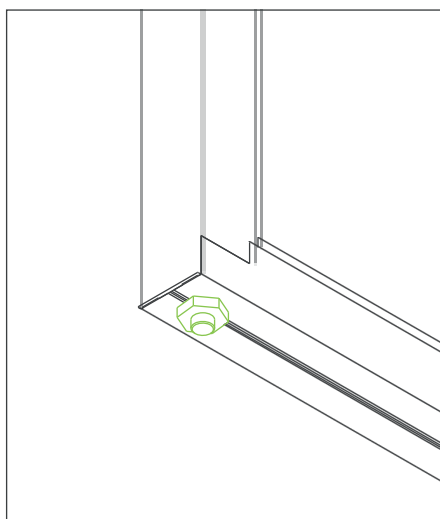

GROUND PIN

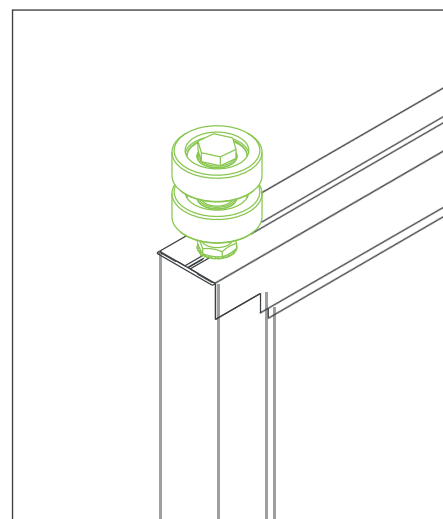

TROLLEY Ø40 mm

## RAIL CHECK AND REMOVAL OF THE DEMOUNTABLE PIECE

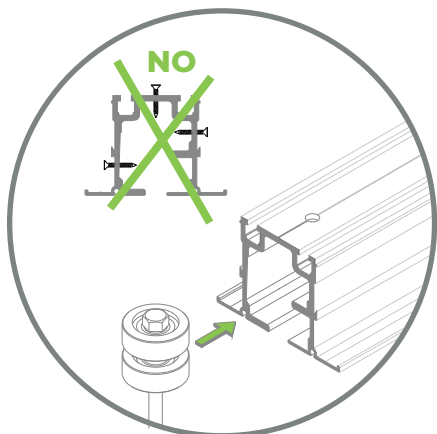

Check that the rail is clean, undamaged and/or obstructed

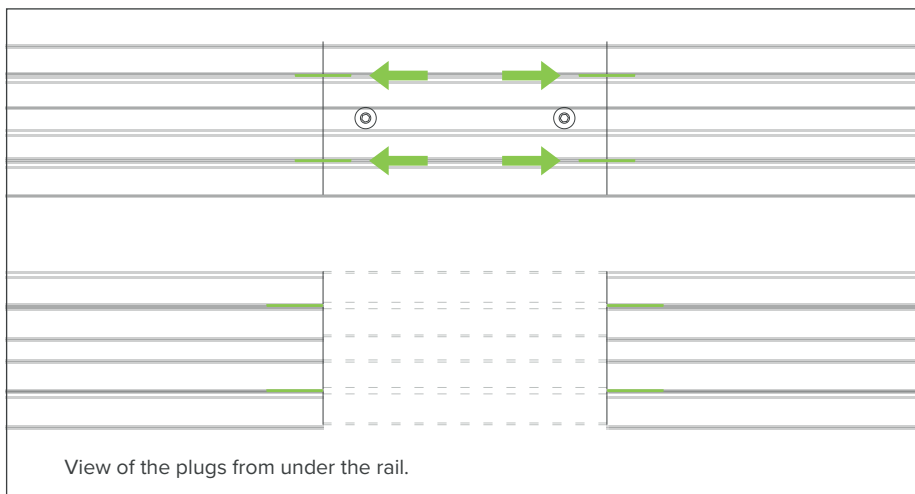

View of the plugs from under the rail.

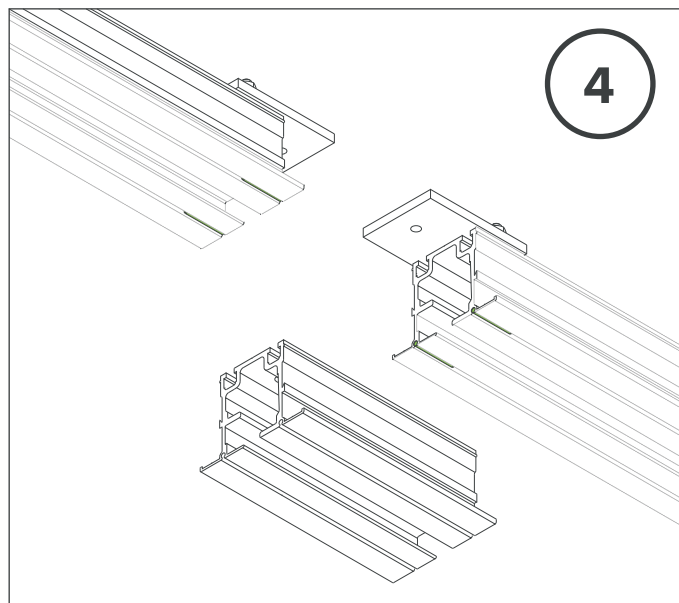
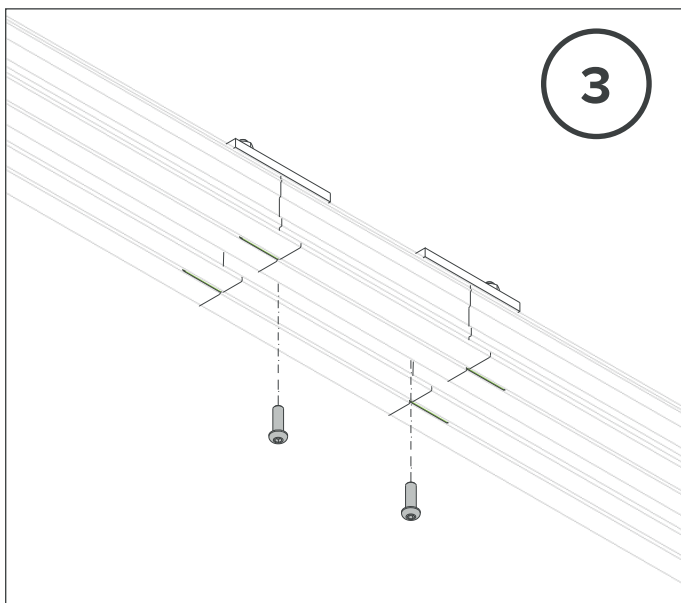
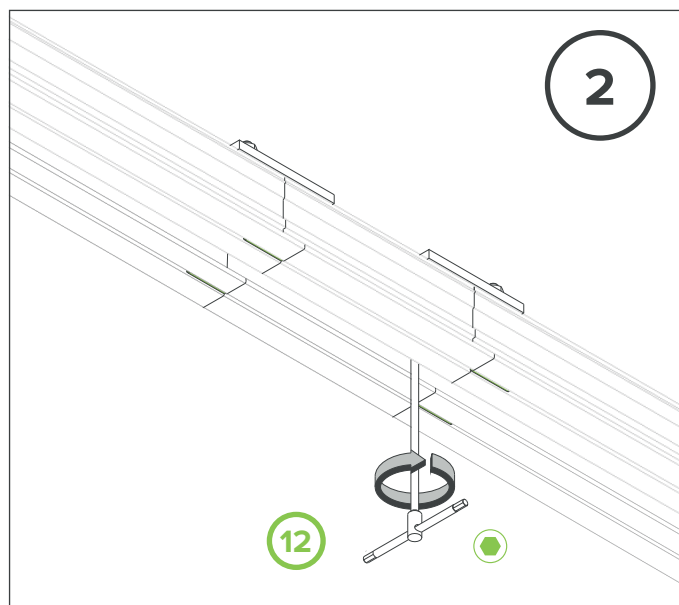
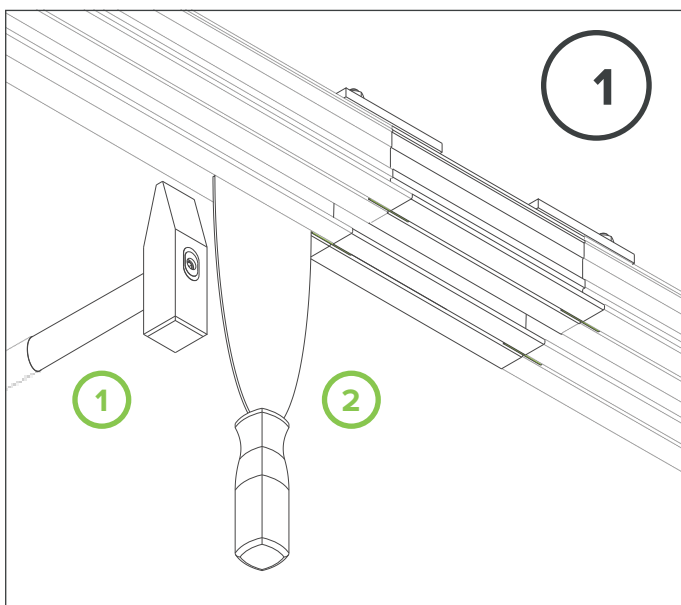

## GROUND PLATE FIXING

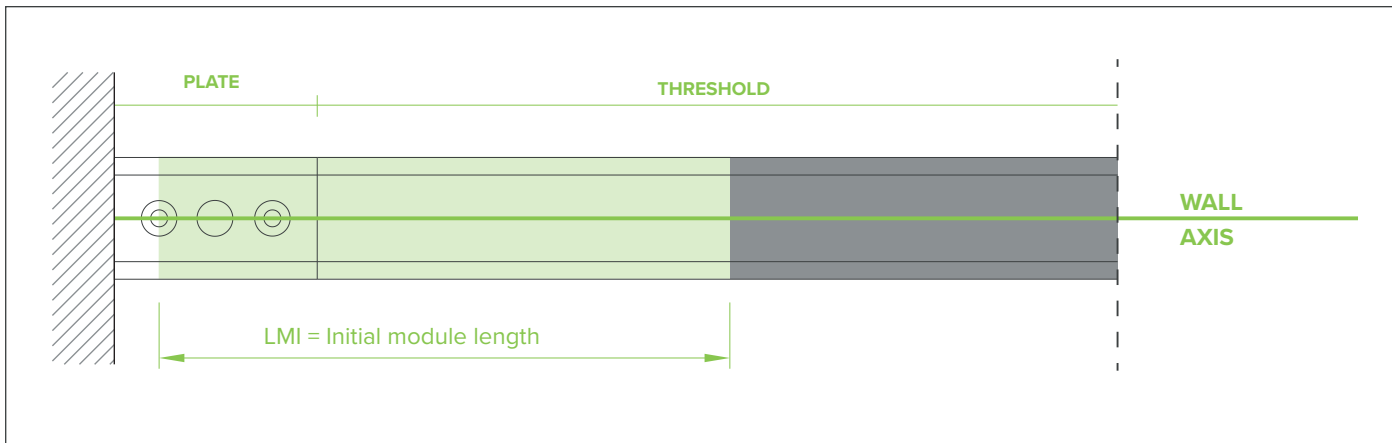

X 1

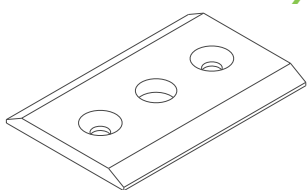

COD.  
400015

HARDWARE USED

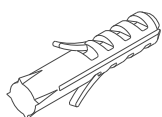

X 2

COD.  
04202.0636

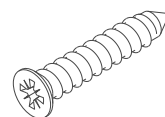

X 2

COD.  
01207.40045

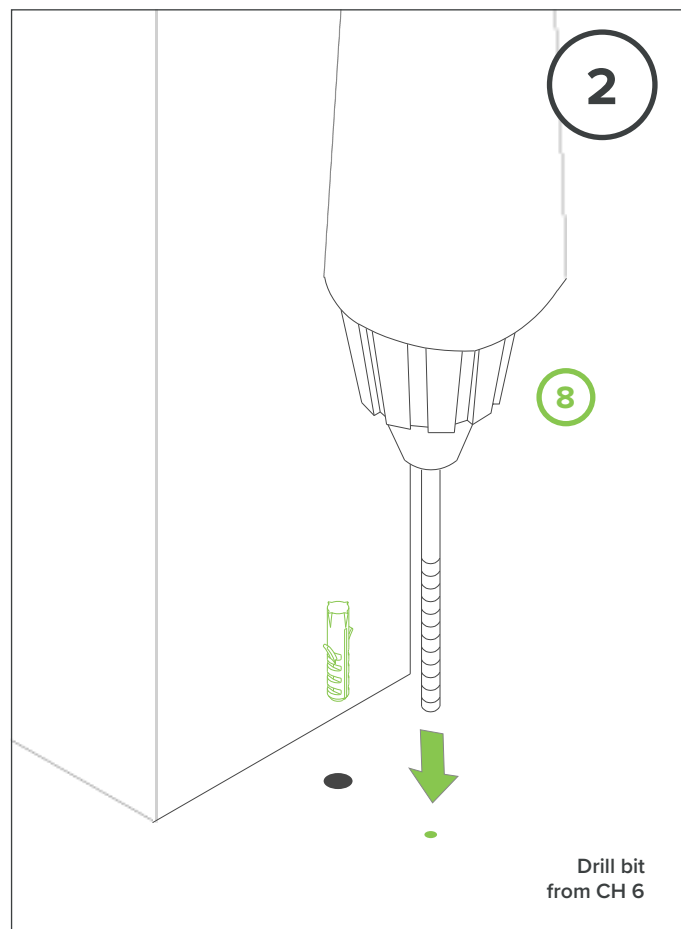
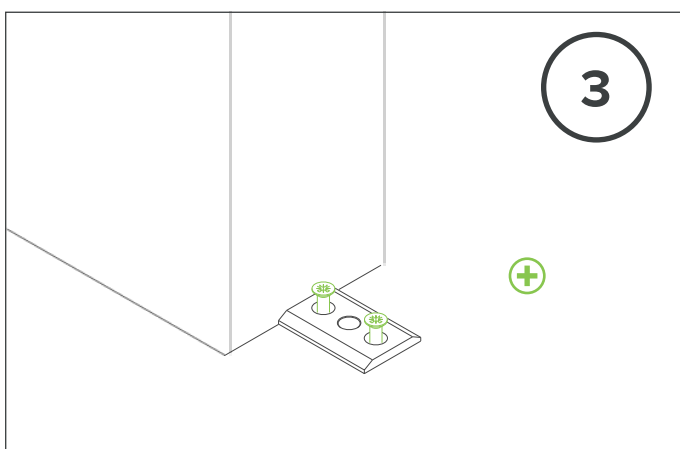
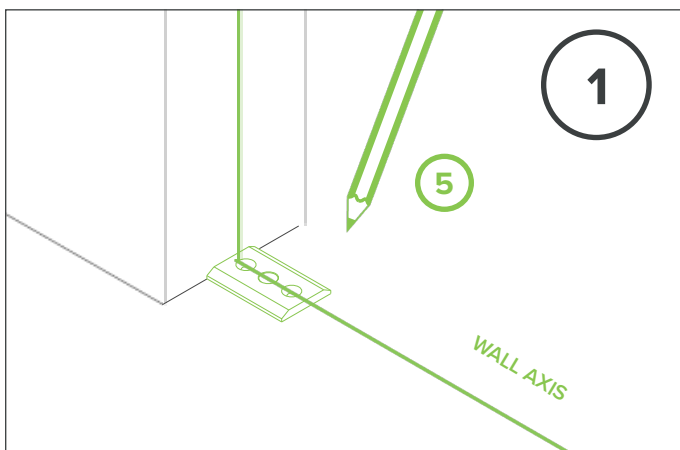

!!! WARNING !!! If underfloor heating present  
evaluate depth for holes

## ASSEMBLY OF THE INITIAL MODULE

Insert both setscrew before mounting the initial module.

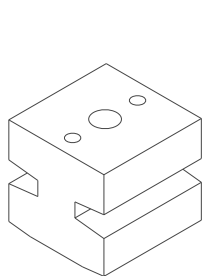

X 1

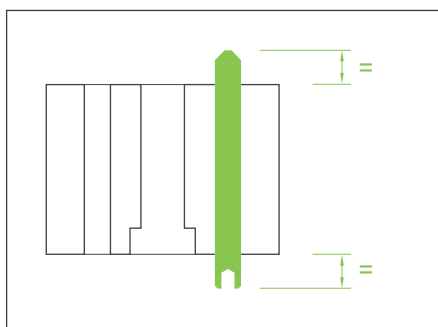

HARDWARE USED

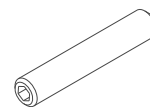

X 1

COD.  
400012.1

COD.  
03801.06050

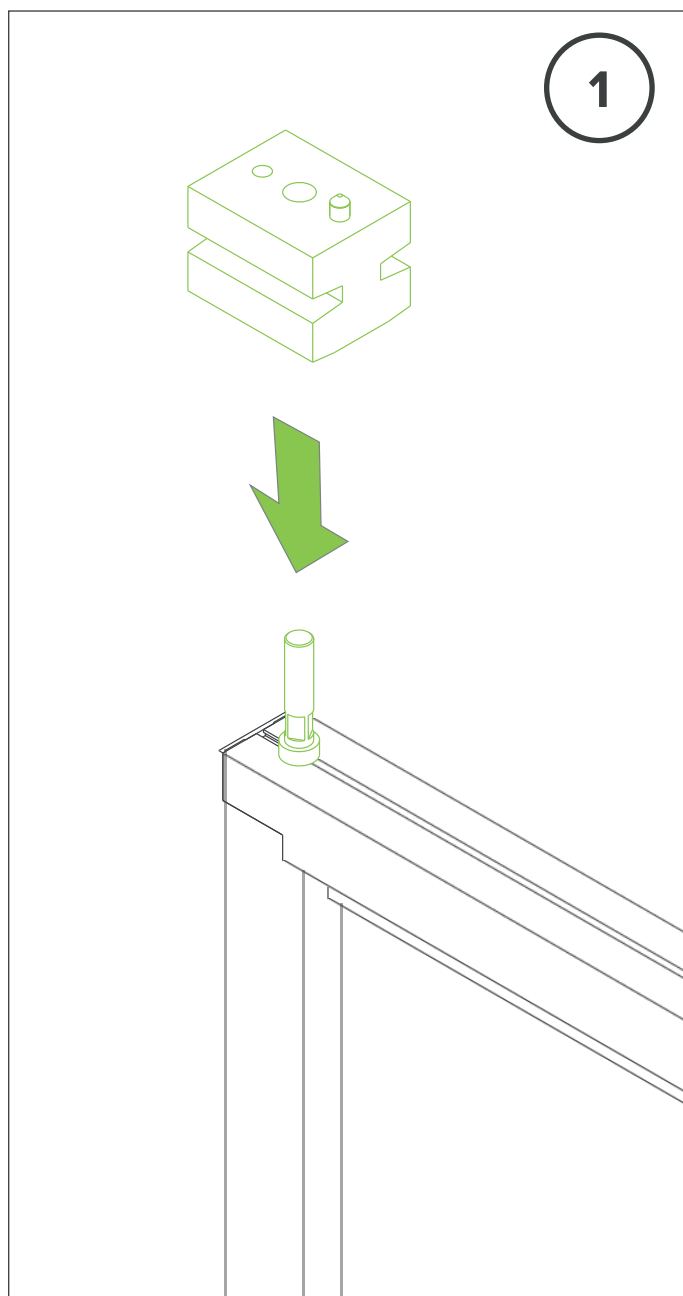

1

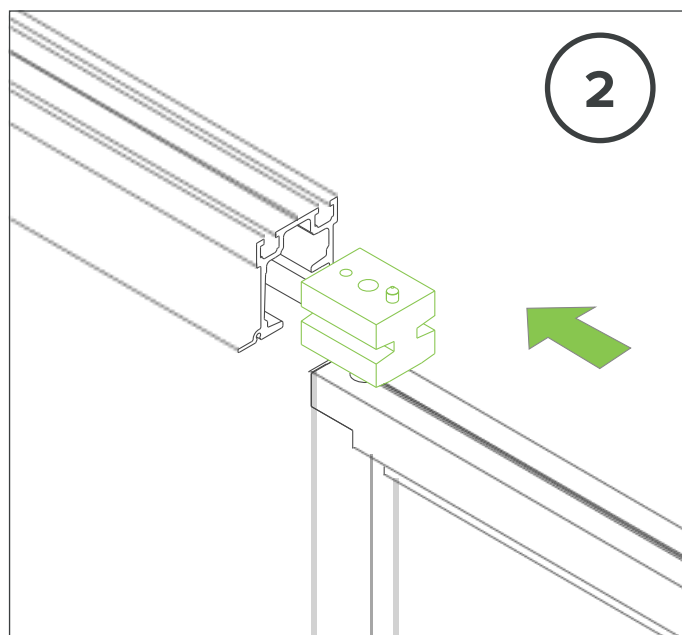

2

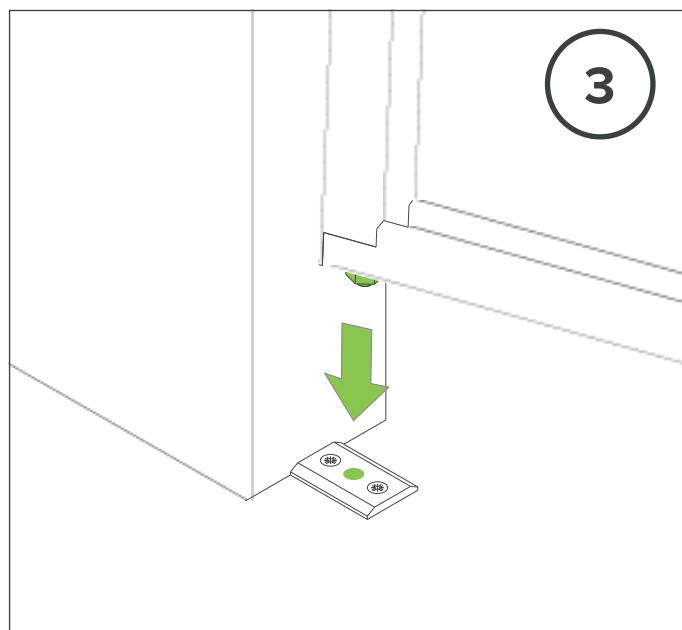

3



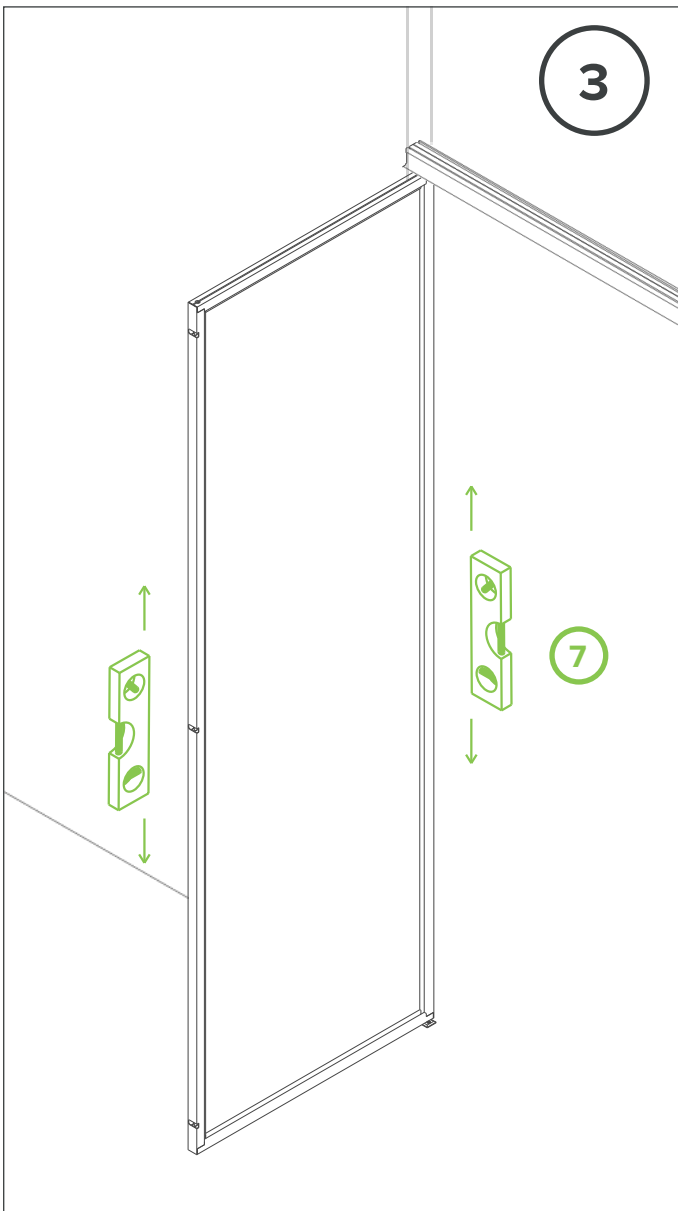

The form must be plumb on both axes in both cases before attaching the beads.

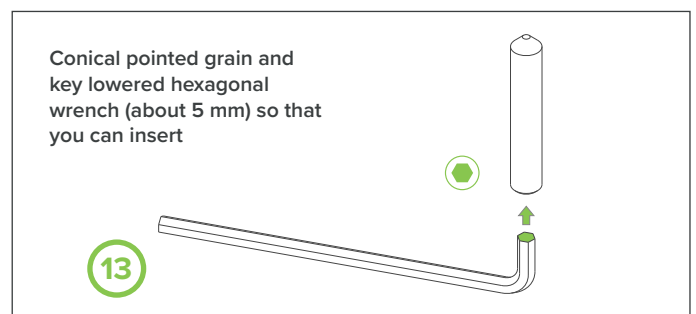
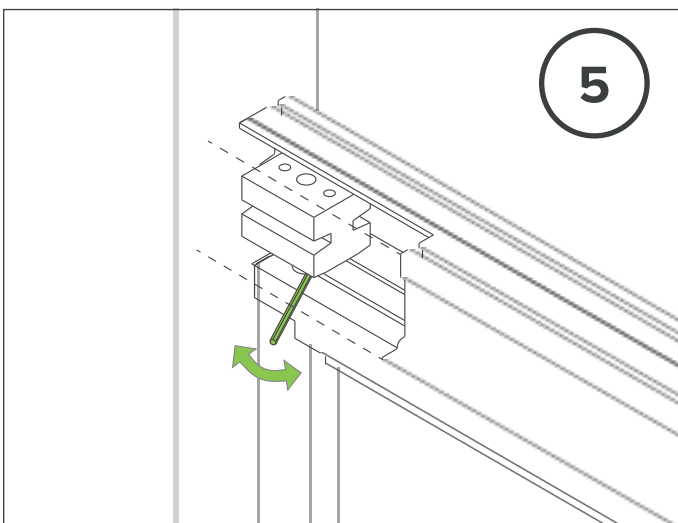

## INSERTION OF FINAL MODULE

Before inserting the module remember to protect the floor.

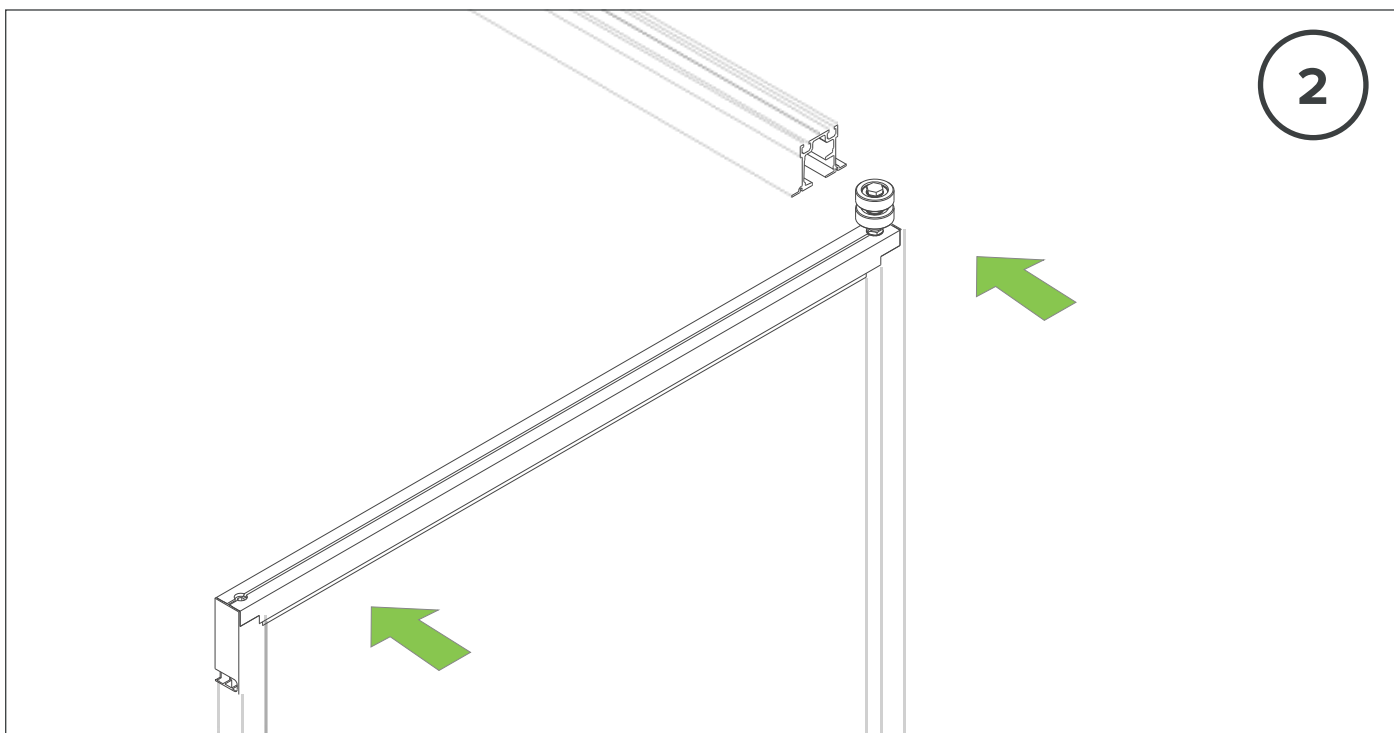
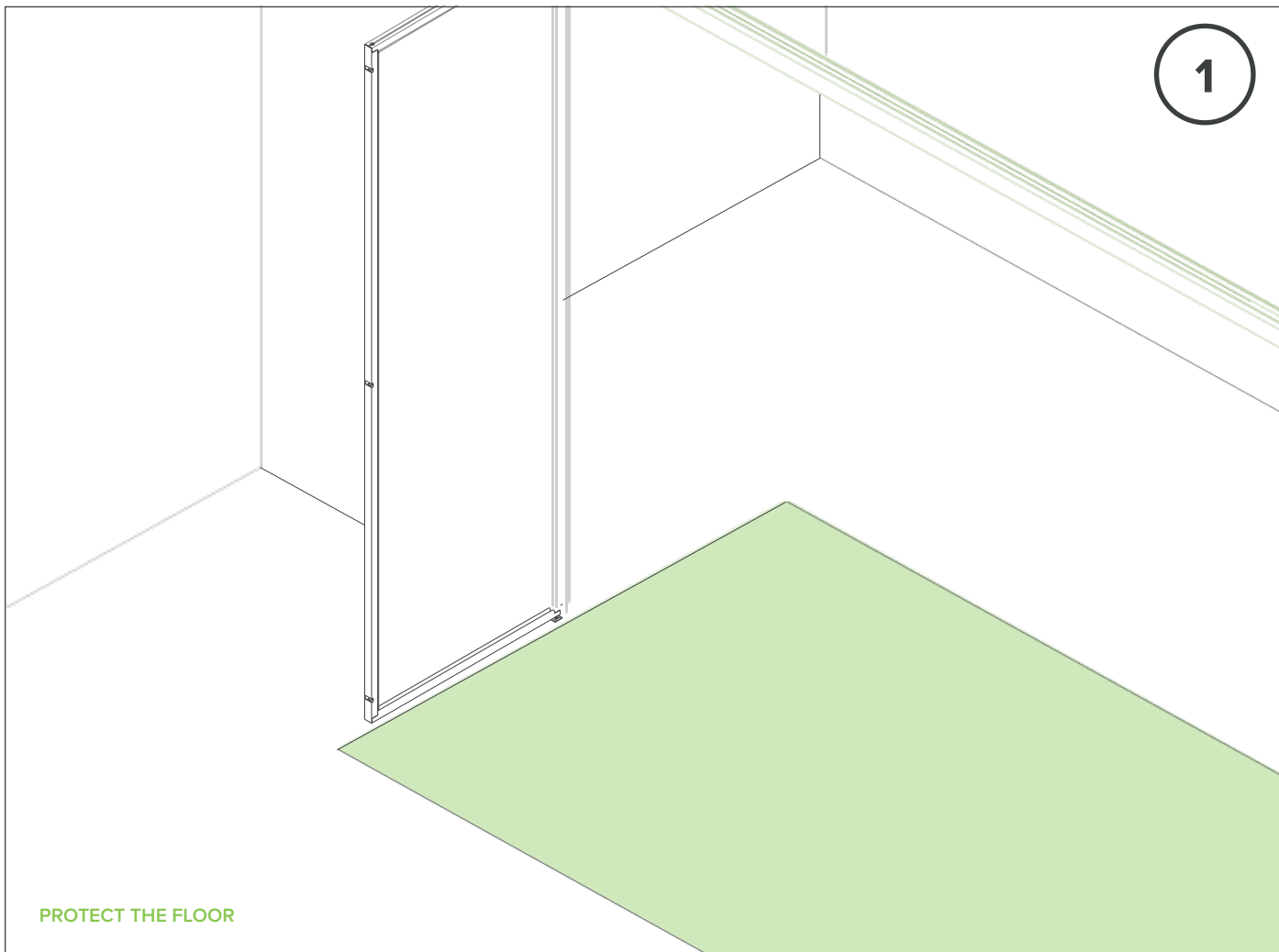

3



Check the correct order of entry  
on the project and from the  
numbers on the forms

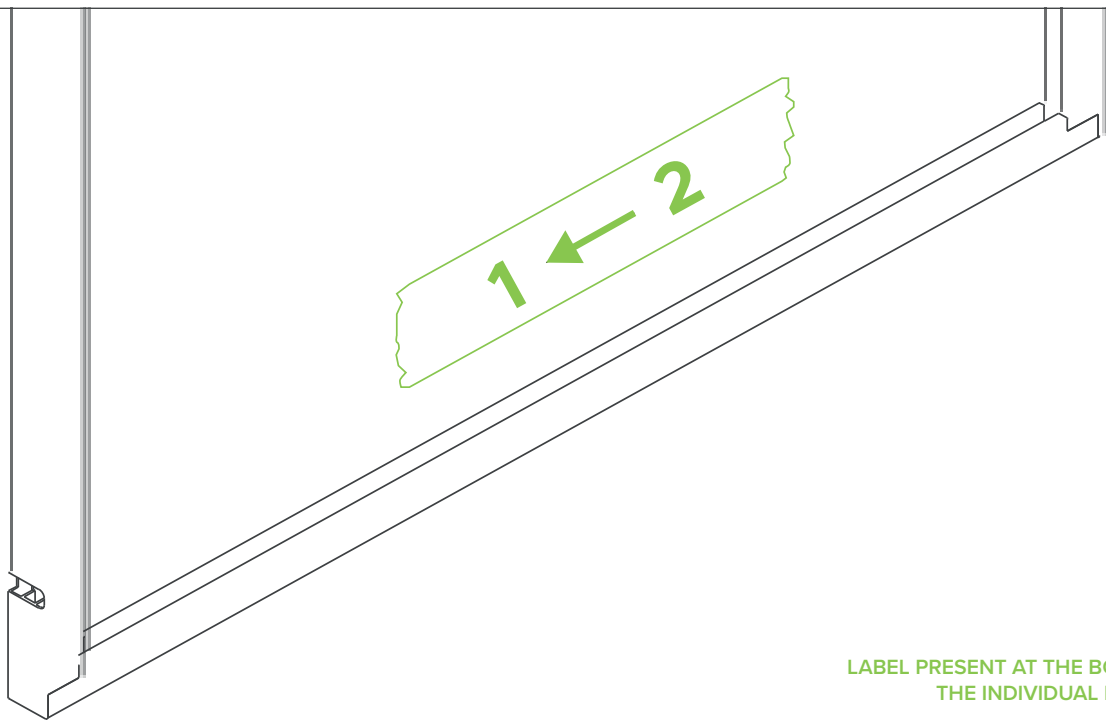
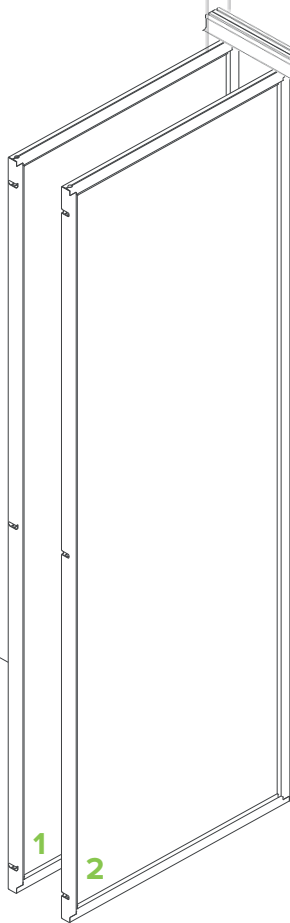

LABEL PRESENT AT THE BOTTOM OF  
THE INDIVIDUAL MODULES

## REPOSITION THE DEMOUNTABLE

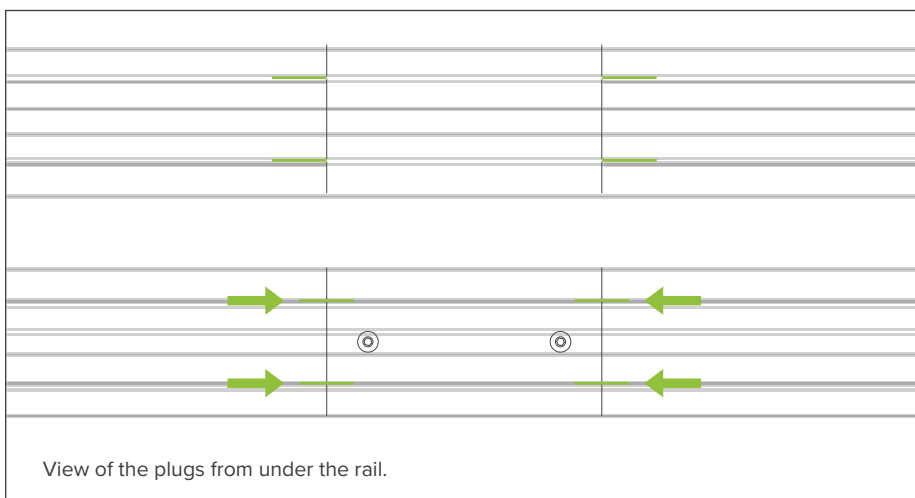
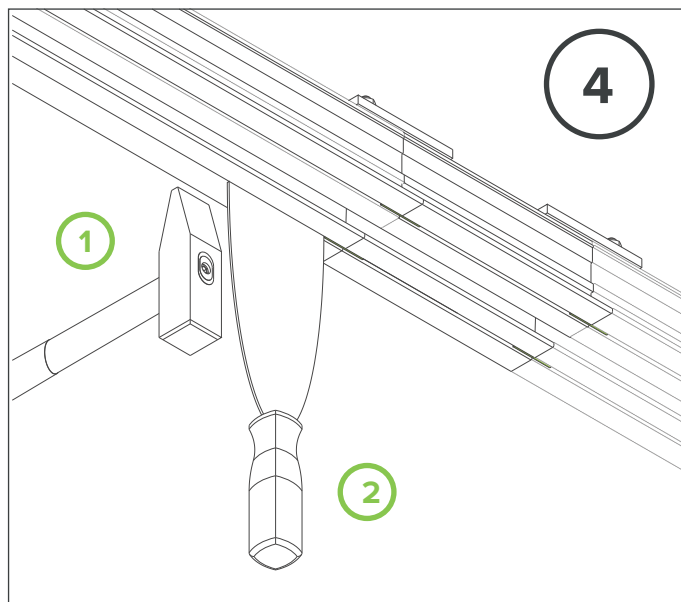
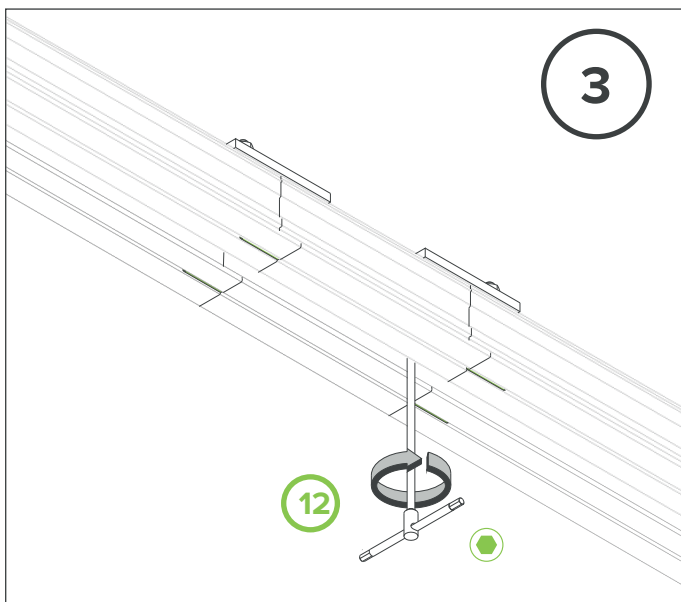
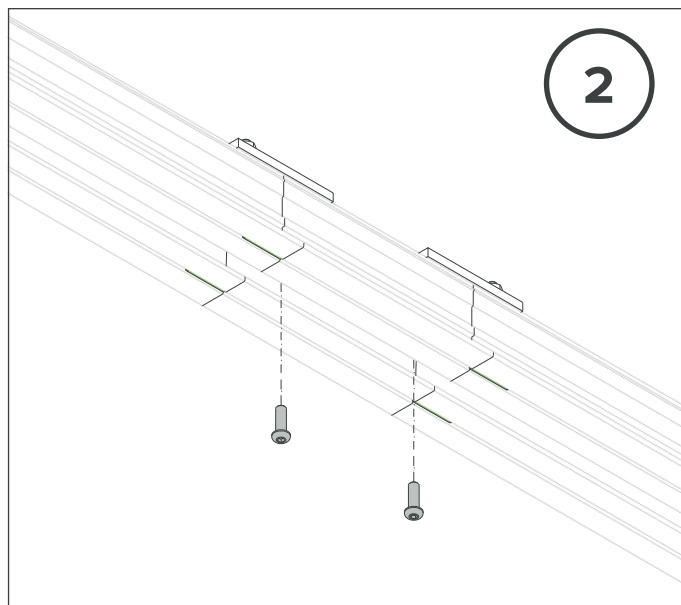
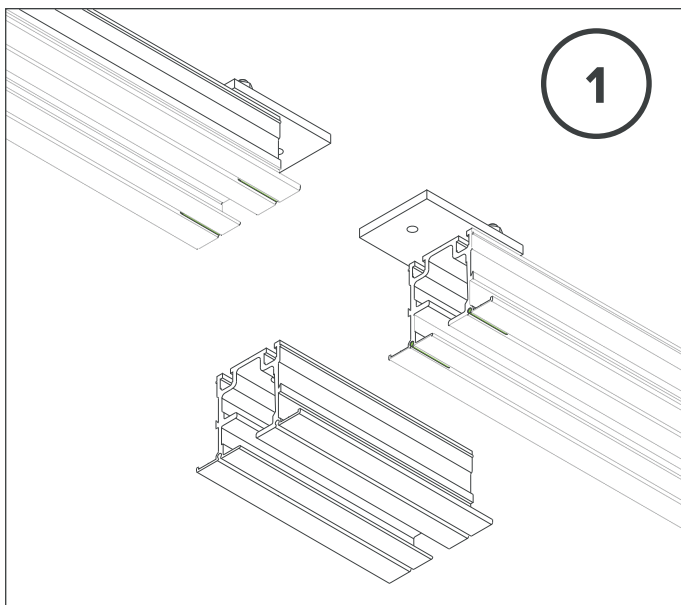

## POSITION OF TROLLEYS AND HINGE SLOTS

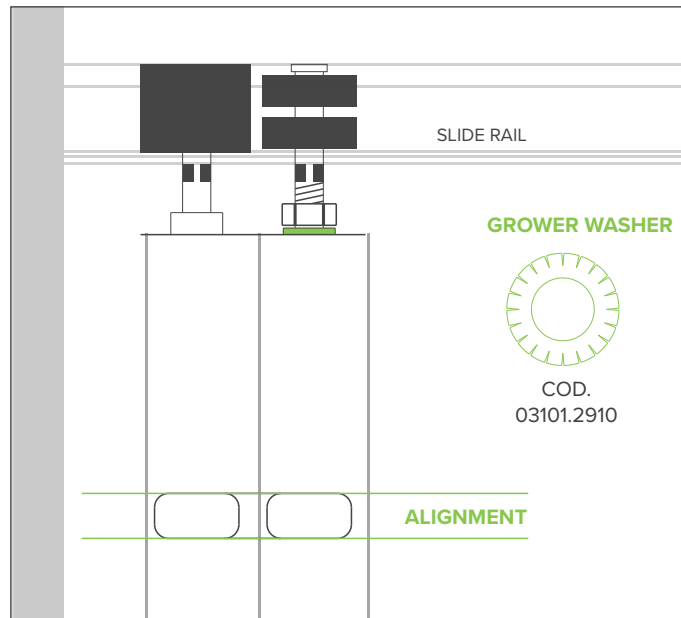
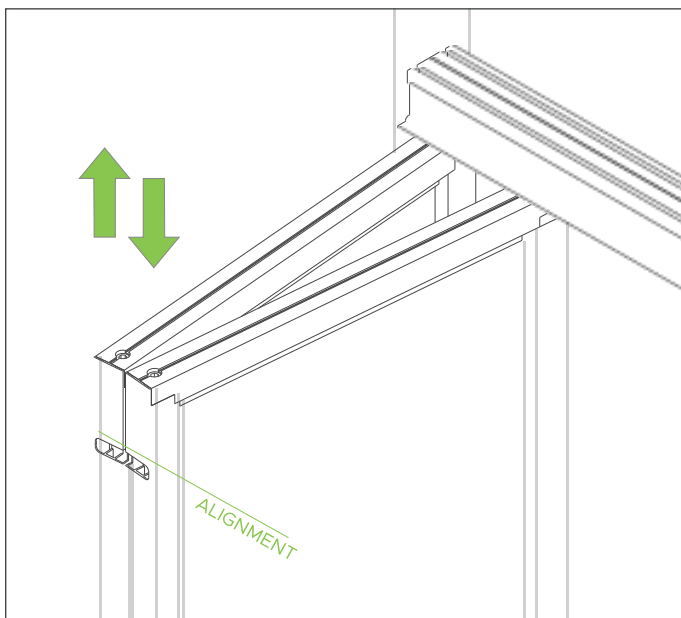
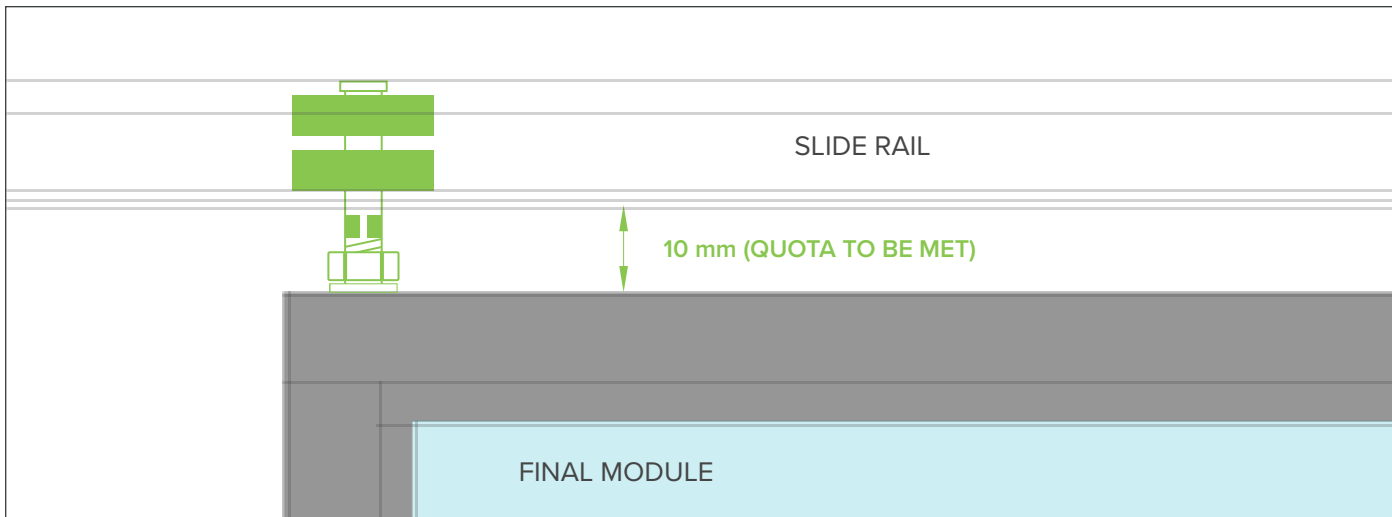

## TO ADJUST THE TROLLEY (if necessary)

Remove the carriage locking screw before adjusting.

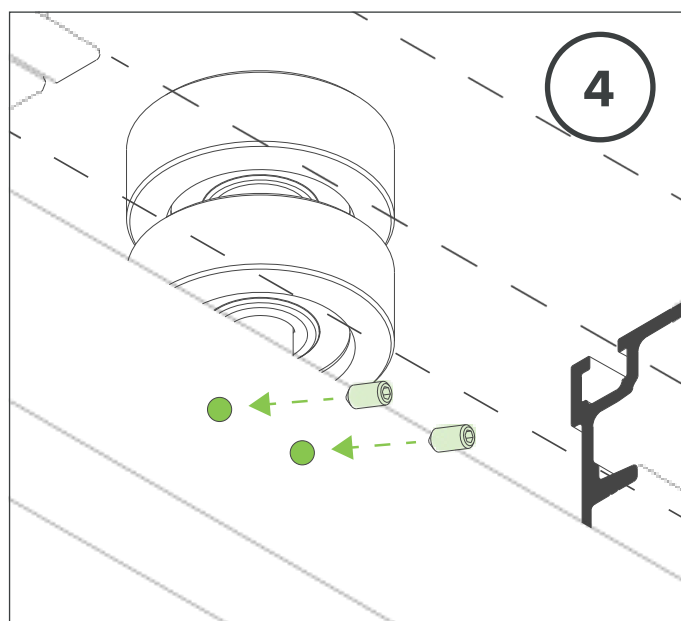
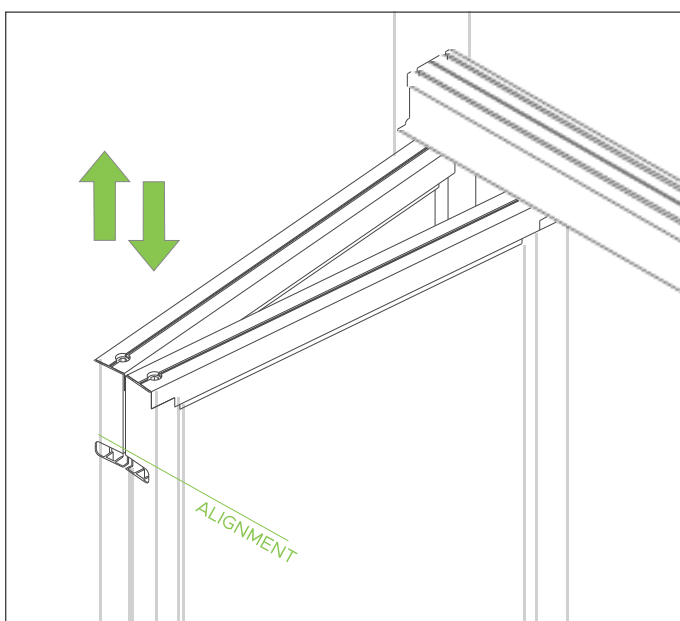
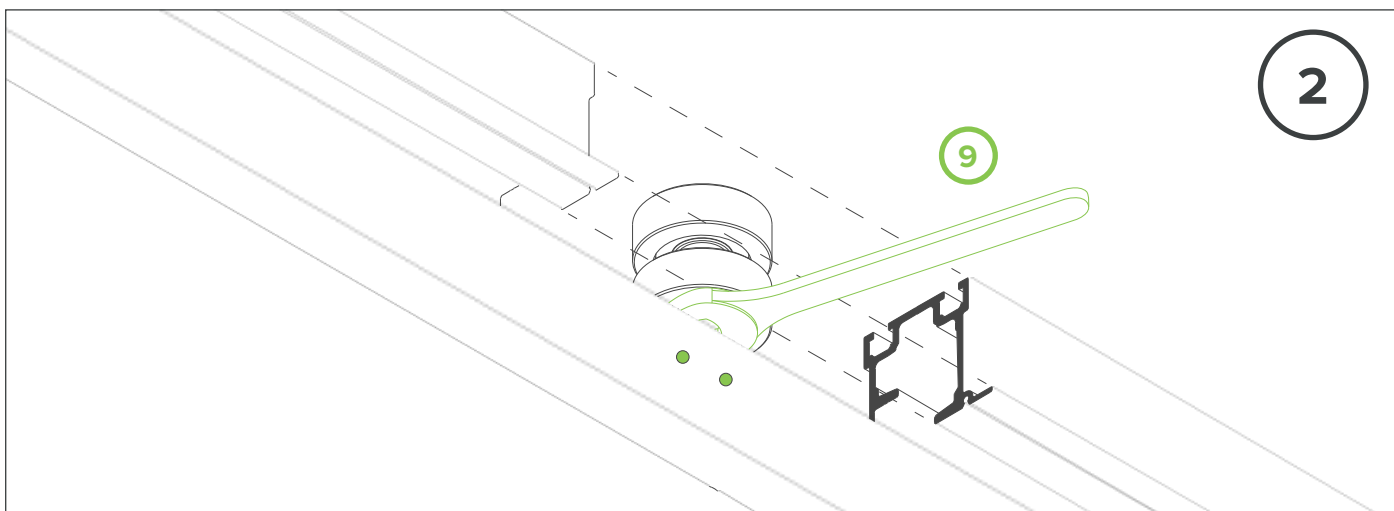
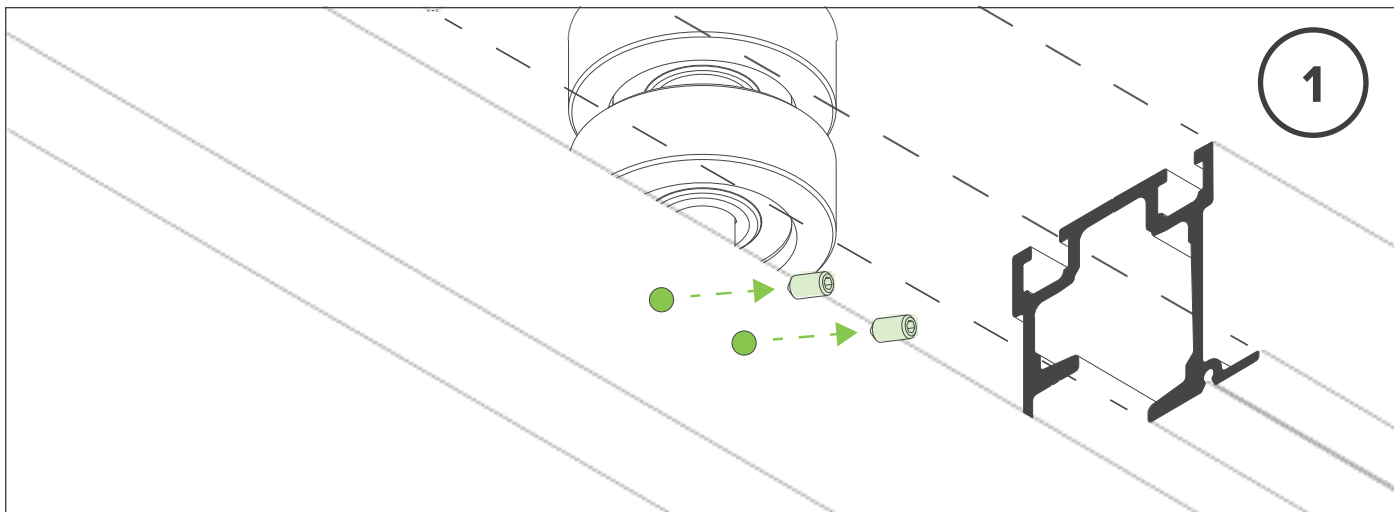

## ASSEMBLY OF HINGES

### HARDWARE USED

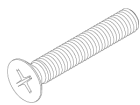

X 6

COD.  
01702.05030  
01702.5030I

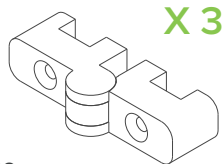

X 3

COD.  
400008  
400008.1

### CORRECT POSITION OF HINGES

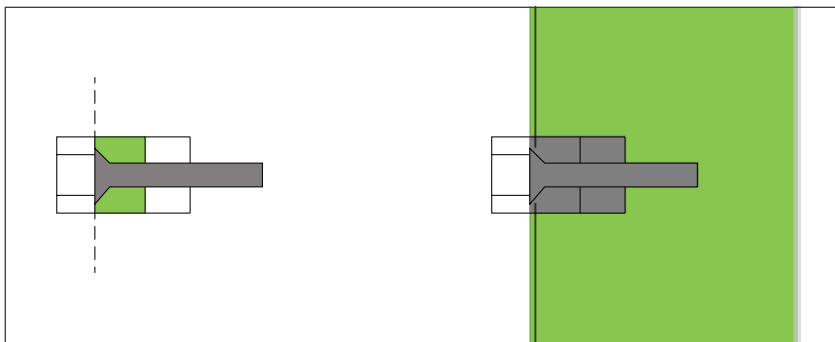
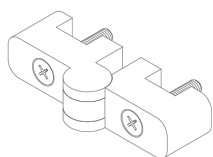

### IMPORTANT

THE SCREW MUST BE COPLANAR TO THE HINGE. THE  
HINGE MUST BE COPLANAR TO THE PROFILE.

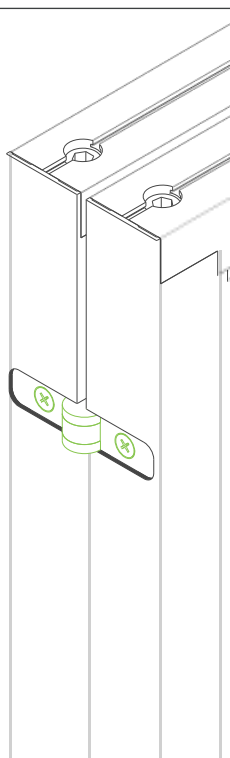

NO

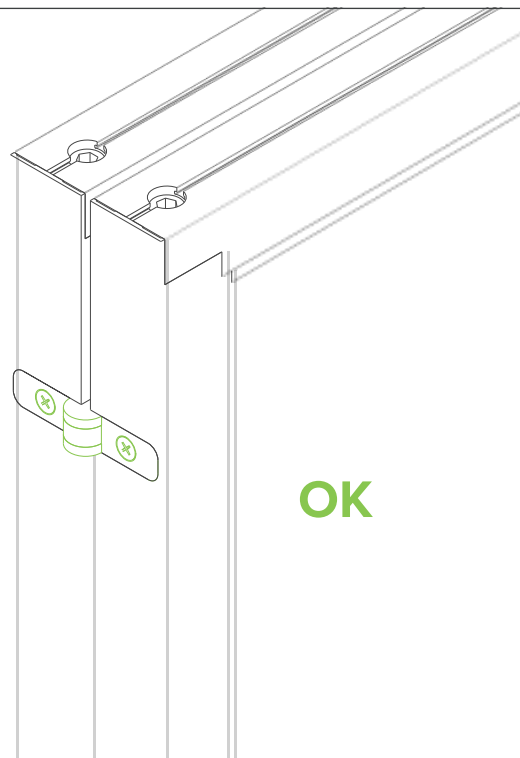

OK

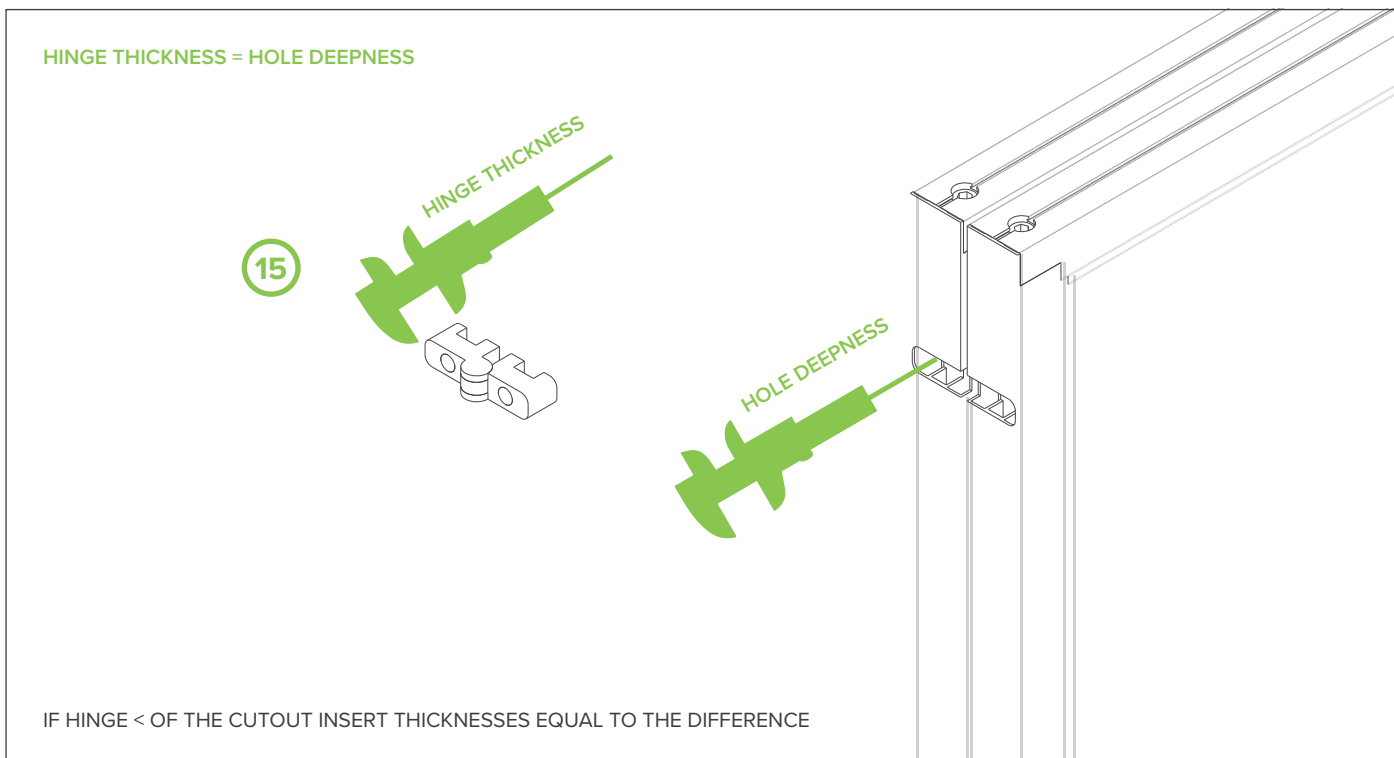
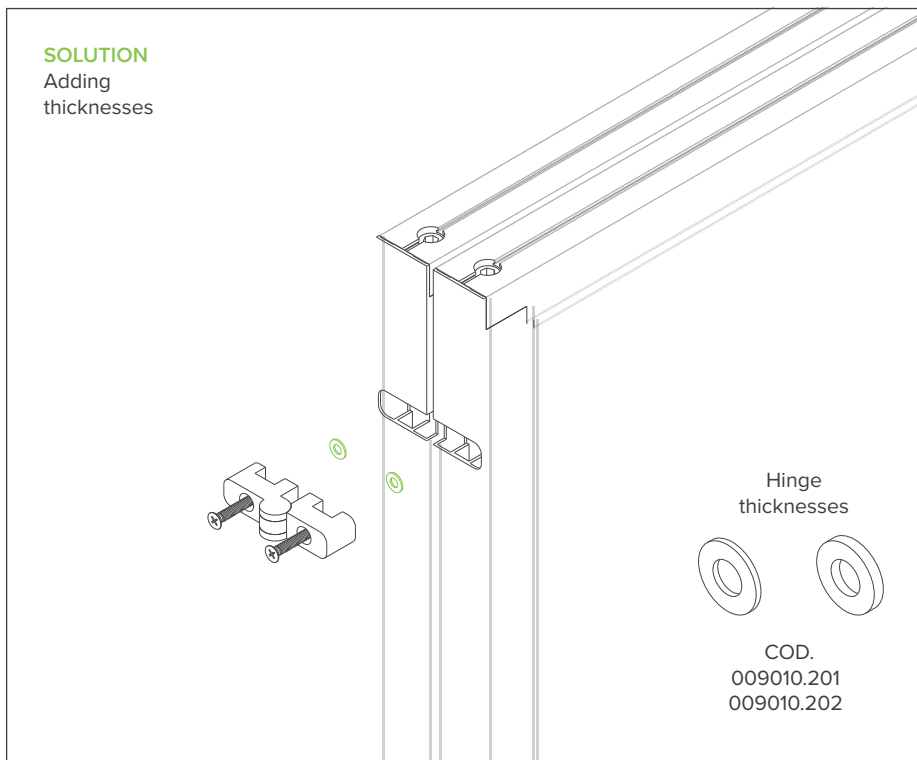
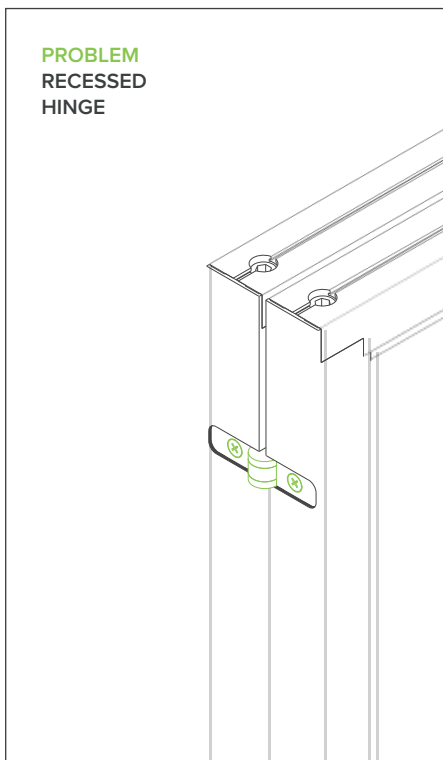



## CORRECT REMOVAL OF HINGES

How to remove hinges without ruining profiles.

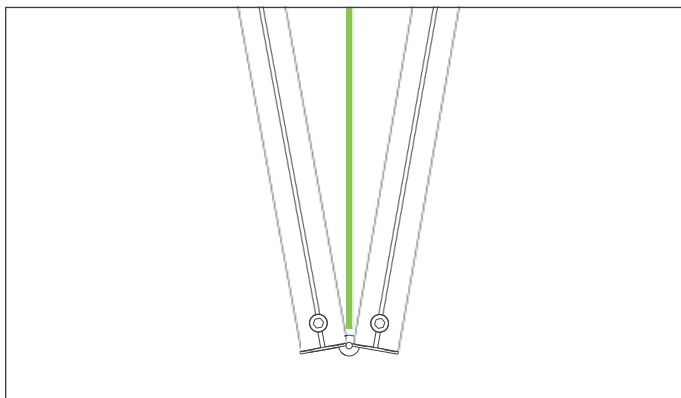

POSITION OF MODULES TOP VIEW

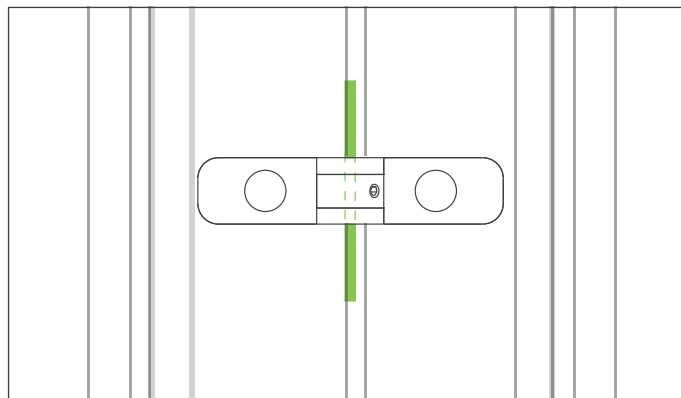

MDF POSITION FRONT VIEW

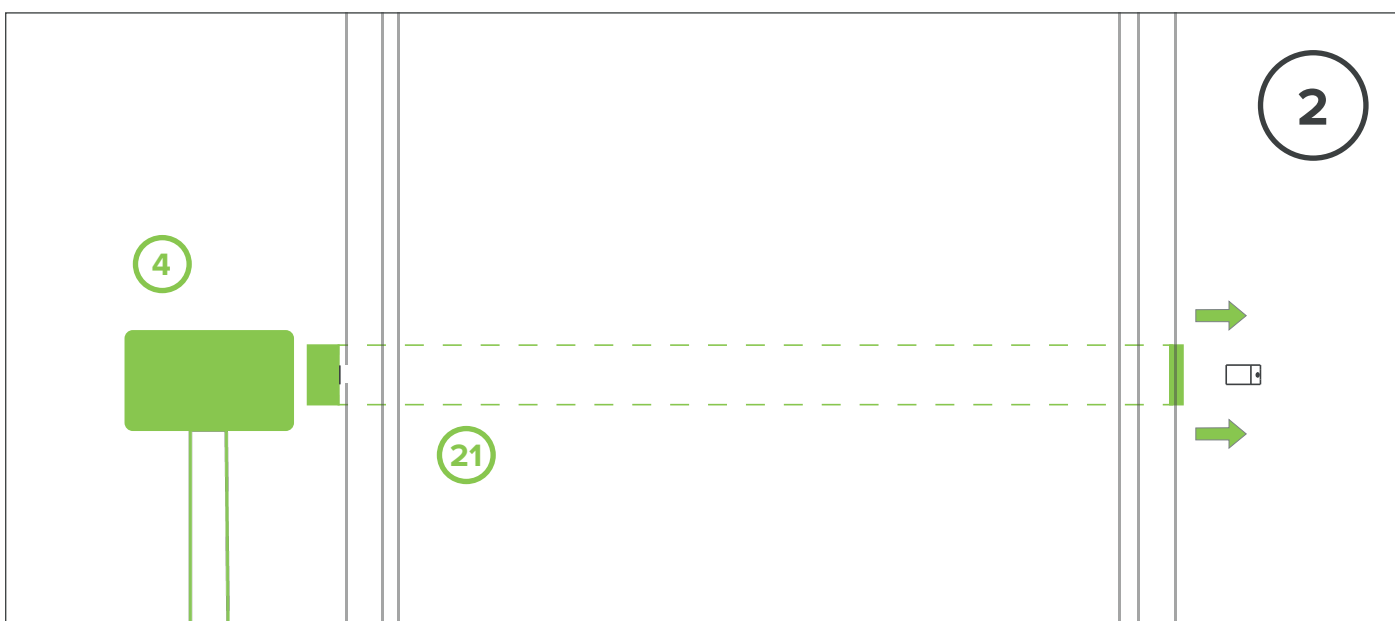
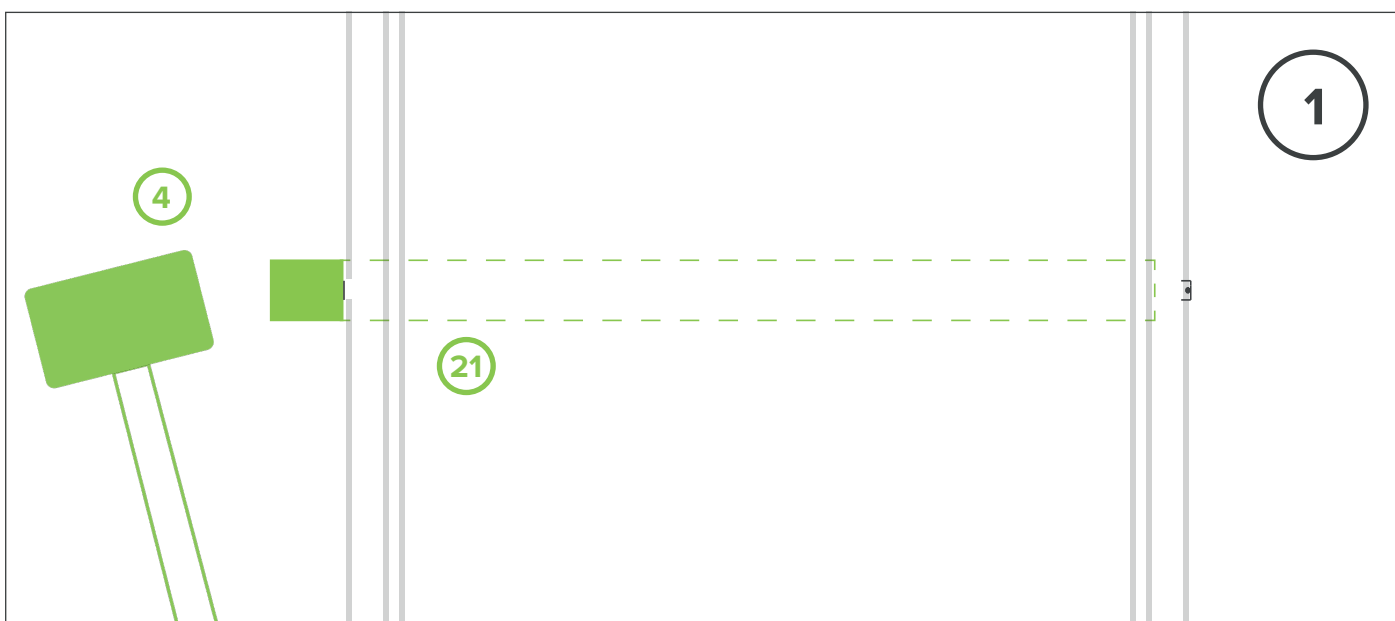

## TEST THE CORRECT FUNCTIONING

Once you have finished assembly, check the wall for proper wall distension.

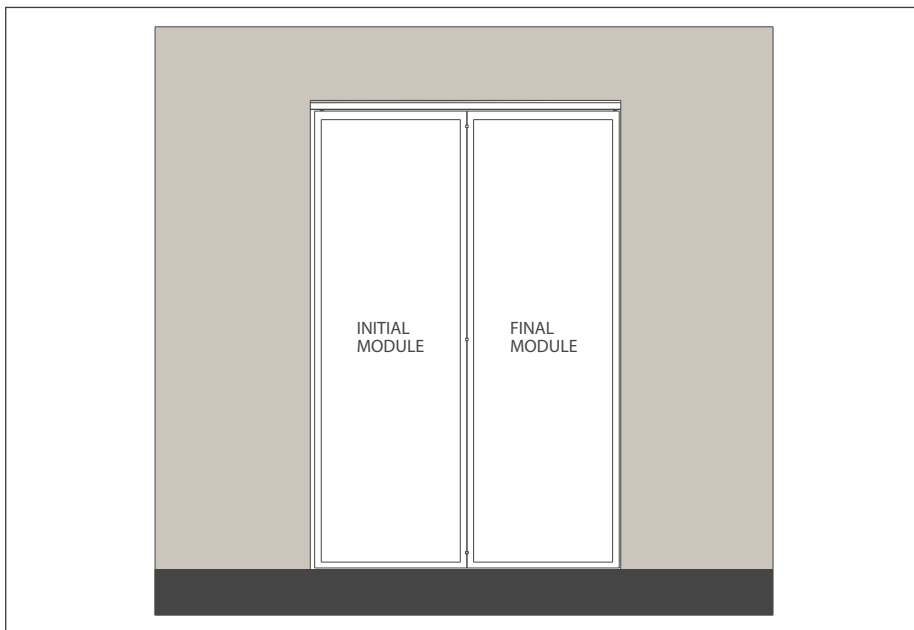

**WRONG** wall distension



**CORRECT** distension of the wall

If distension problems occur, check that the hinges are installed correctly. (SEE P. 14-15)

### CORRECT POSITION OF HINGES

#### IMPORTANT

the screw head must be perfectly flush with the hinge, the same goes for the hinge on the profile.

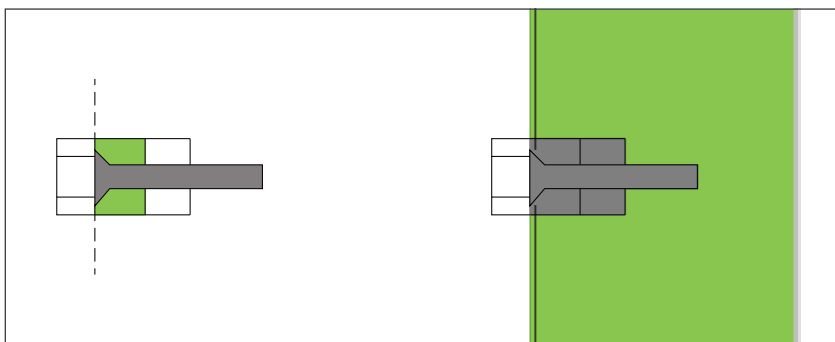
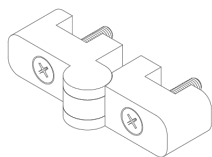

## THRESHOLD FIXING

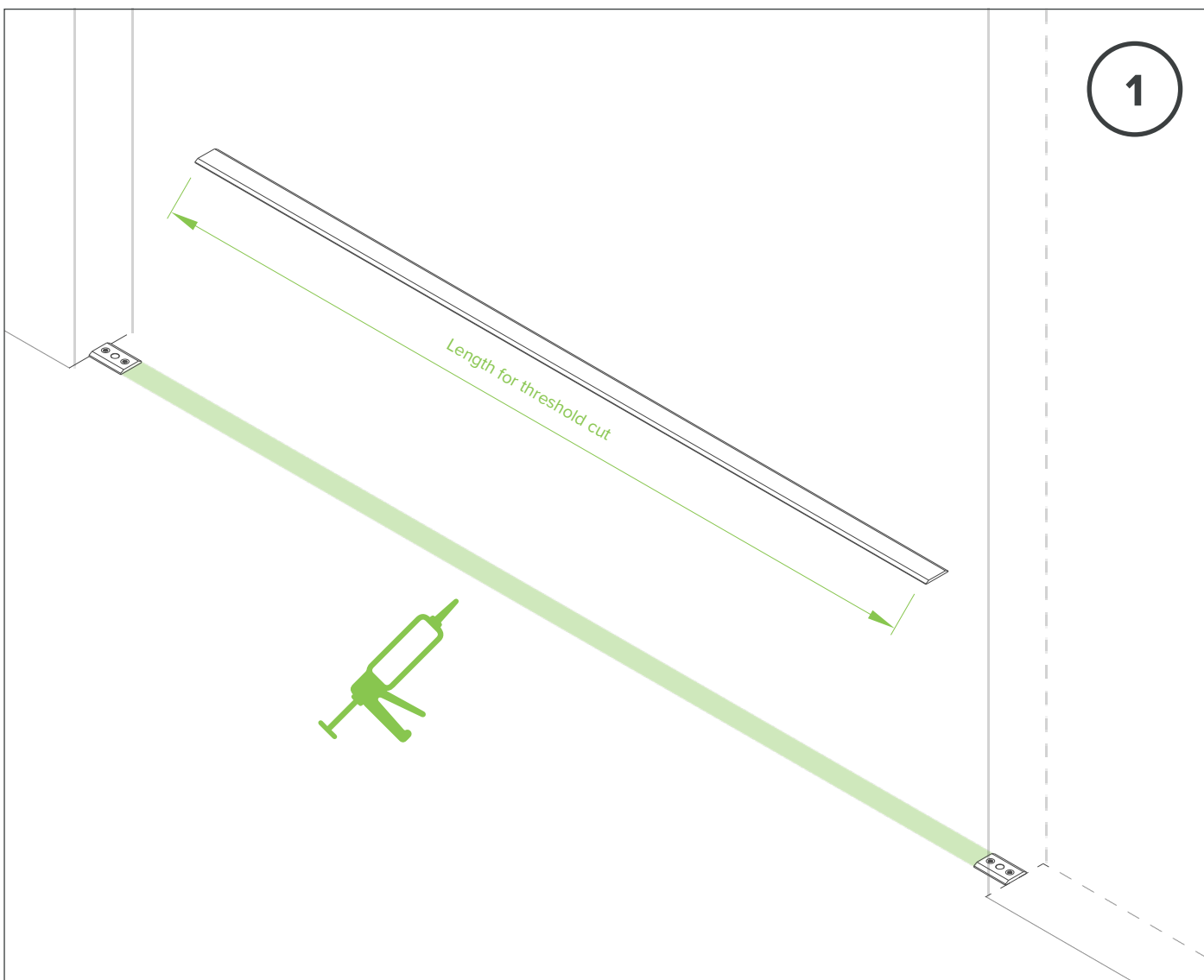
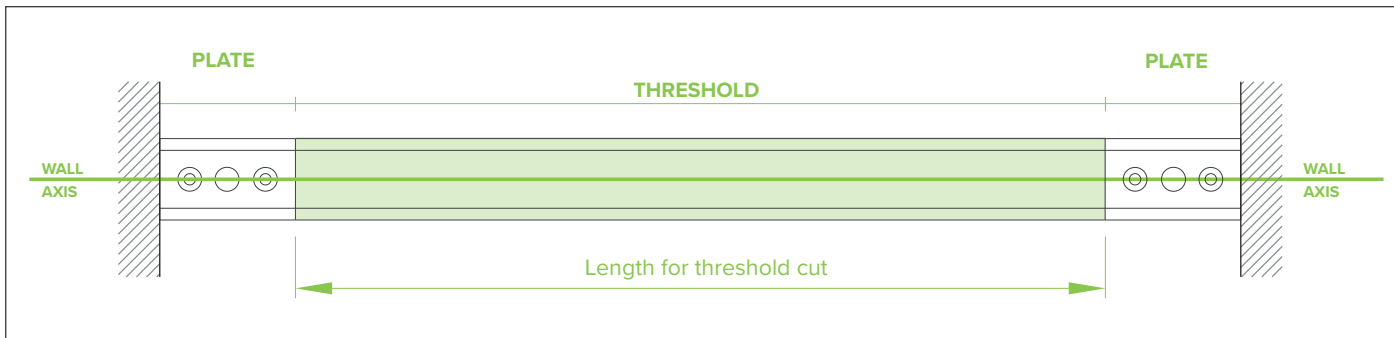

BEFORE PLACING THE THRESHOLD, SPREAD A LAYER OF SILICONE ON THE UNDERSIDE

# HOLES FOR PIN ON THRESHOLD

**!!! WARNING !!!**

Wait at least 12 hours before proceeding with the following steps.

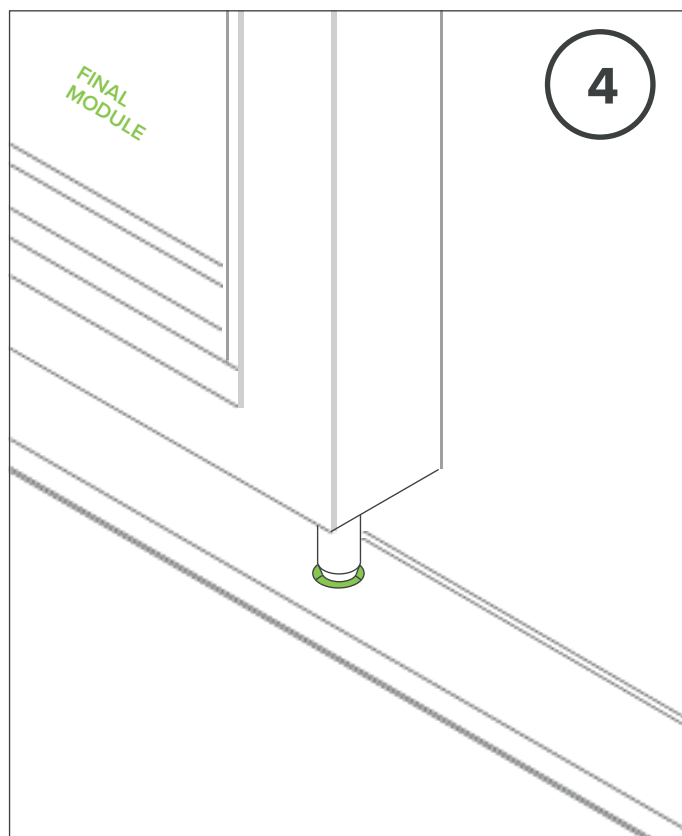
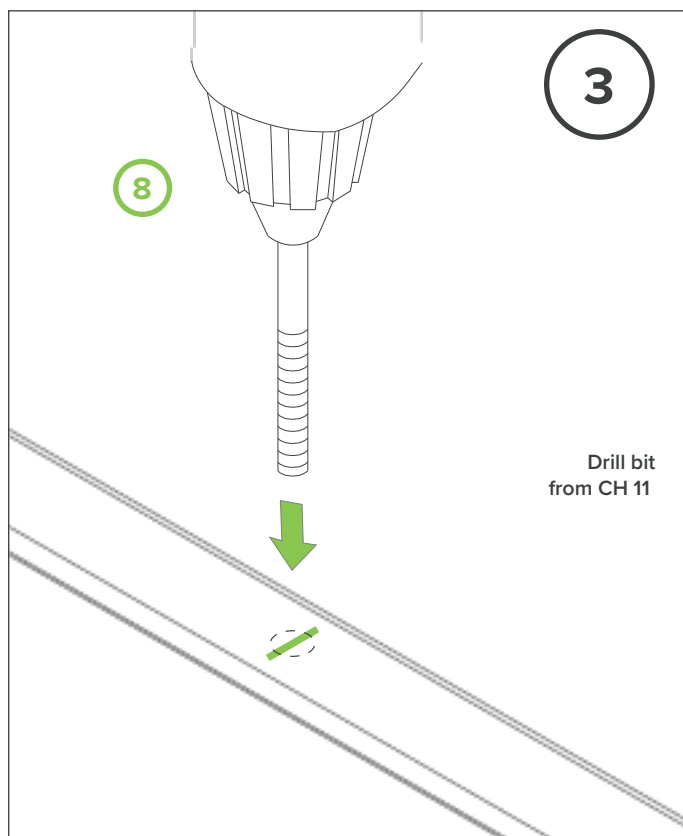
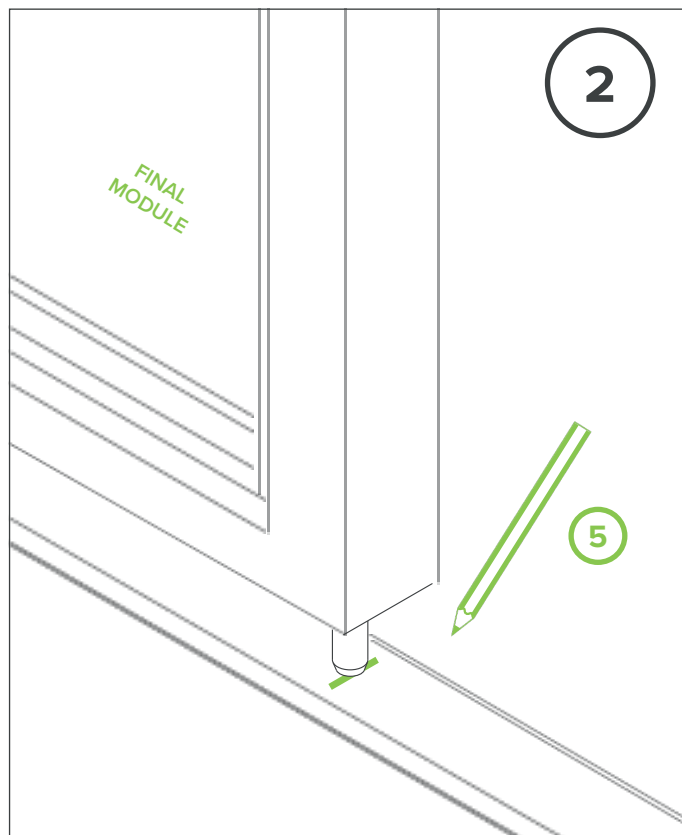
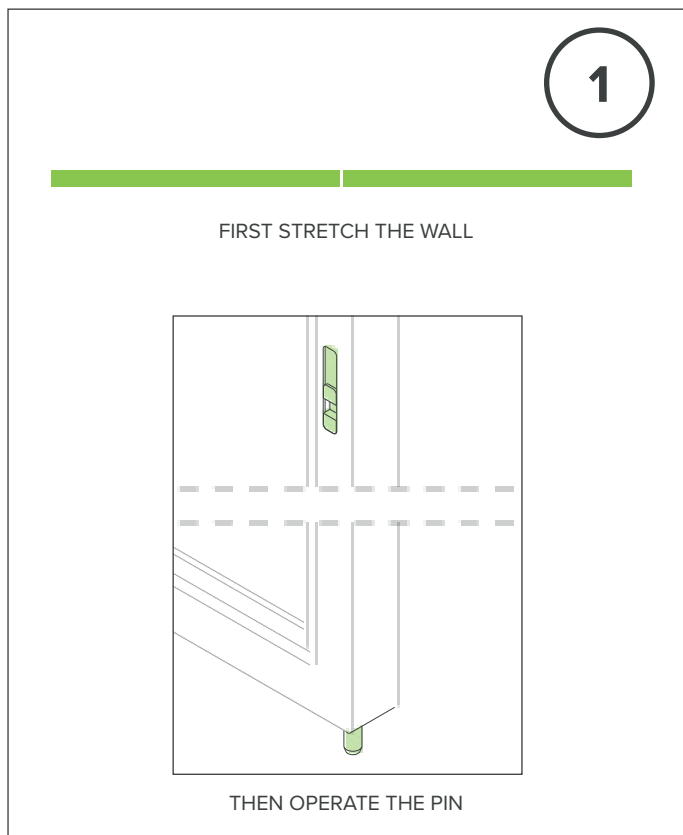

## RAIL LUBRICATION

Apply Vaseline at points about one meter apart.  
Then by operating the wall, the trolleys will distribute the lubricant within the entire rail.

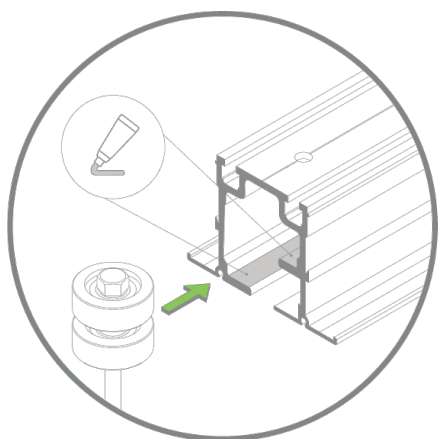
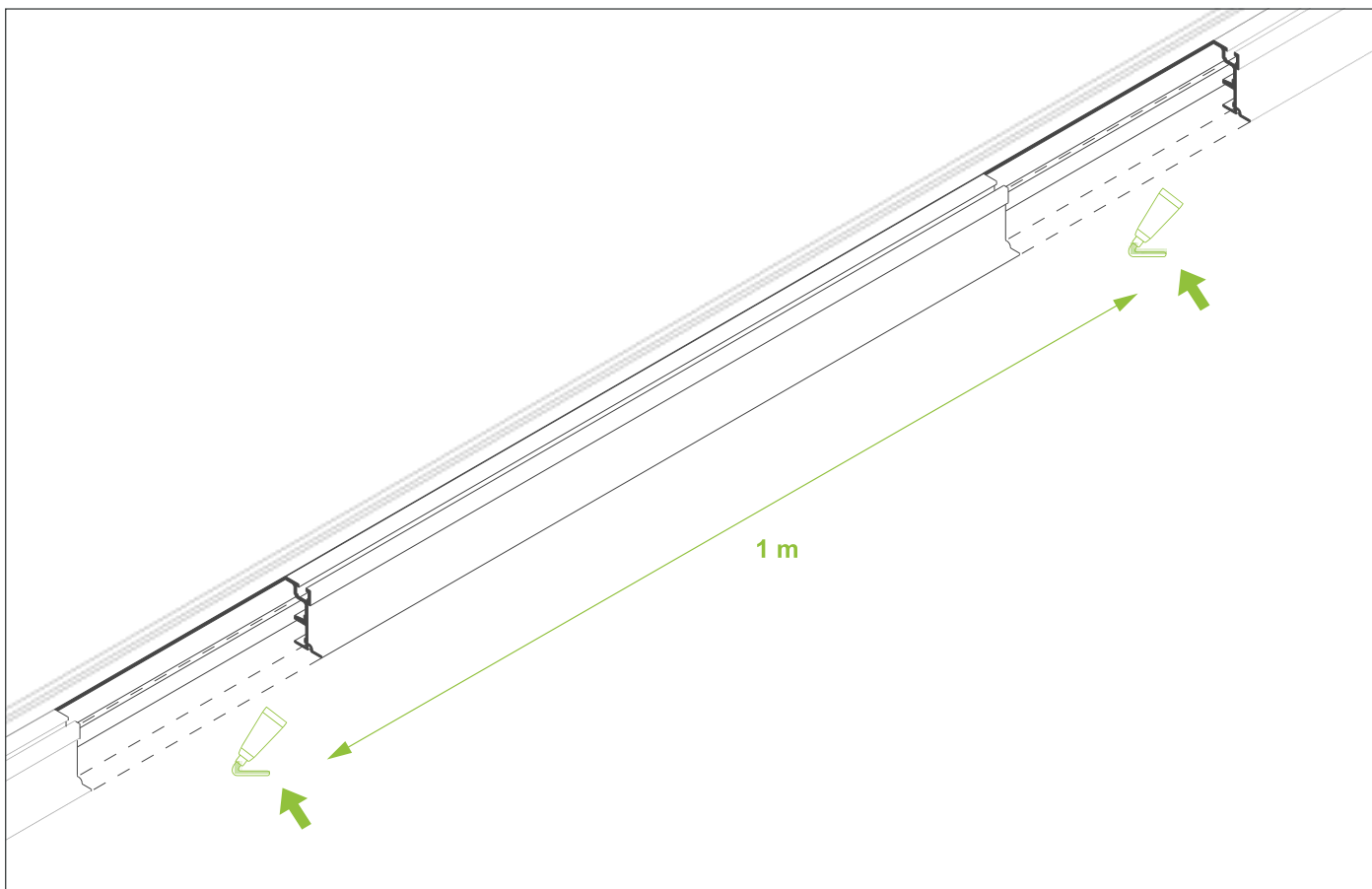

Rail flaps where to spread the Vaseline

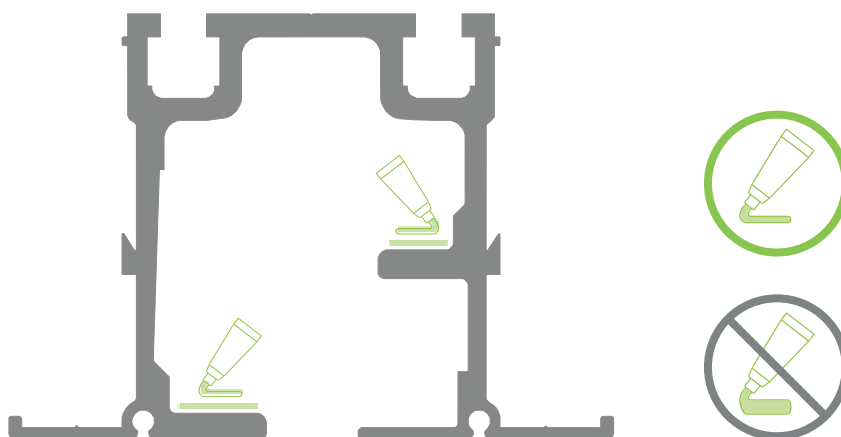

Section of the slide rail  
Where to spread the light layer of Vaseline

## USE AND MAINTENANCE

Before using the wall, read the manual carefully and keep it.  
Modules should be handled in the correct sequence.

### COMMERCIAL NAME

**AURA ZIP the glass aluminum folding partition**  
typology: folding sliding wall

### MATERIALS USED

#### Description

Folding sliding wall consisting of modules hinged to each other, composed of at least two modules, one of which is always anchored to the slide rail and to the floor; with slide rail only on the ceiling.

#### Frame

Aluminum frame, anodized 10-micron thick, powder-coated or liquid-coated according to the chosen color.

#### Glass

Laminated glass 44.1.

#### Panel

Chipboard panel, 16 mm thick, density 720 kg/sqm, CE, Fire Resistance Class B-s1, d0, Formaldehyde Emission Class E1, VOC free, inserted into the aluminum frame.

#### Slide rails

The rails are ceiling-mounted only and are made of aluminum painted white RAL 9010 20/30 Gloss.

### FINISHES

#### Frame

- Silver or champagne oxidized aluminum
- Painted RAL matte or metallic
- Painted in any RAL or NCS color

#### Glass

Float, extra-clear, satin-finished white, milk white, colored PVB, bronze, acid-etched bronze, reflective bronze, smoked, acid-etched smoked, reflective smoked, flute, fabric or wire mesh laminated glass.

#### Panel

- Covered in CPL White, Ivory, Gray
- HPL Colours series
- HPL wood veneer series
- Coated in laminate Polaris series
- HPL coated in Blackboard series
- Covered in HPL magnetic and writable
- Lacquered coating 20/30 gloss

#### Components

Burnished steel  
Niploy

### PRECAUTIONS FOR USE

Avoid improper and inappropriate uses of the product. Any tampering or installation not in accordance with the manufacturer's instructions could compromise product compliance.

### CLEANING AND MAINTENANCE

For perfect maintenance and operation of the product, it is necessary to properly clean the maneuverable wall. Since this is a furniture complement, we recommend the use of products for the home environment, specific to the finishes.

#### SLIDE RAIL

To clean the rail, use products specifically for aluminum. To maintain perfect sliding of the modules, it is advisable to put a light coat of Vaseline on the two fins of the rail, at least once a year.

#### PROFILES

When cleaning aluminum profiles, use products specifically for aluminum. Do not use solvents or abrasive pastes as they may cause them to lose their shine or be irreparably damaged. Aluminum profiles should not be subjected to shocks or blows: incorrect use of the maneuverable wall can cause aluminum profiles to deform, reducing their handling performance.

#### PANELS

For cleaning CPL and HPL surfaces, use furniture-specific neutral products, while for veneer use wood-specific neutral products. For lacquered surfaces, use clean, dry cloths. Infill panels should remain away from moisture.

#### GLASSES

Use glass-specific products to clean glass, and it is important to keep glass dry at all times.

WALL MOVEMENT

(a) Handling from storage area to lying wall

1. Stand in front of the packed wall, embrace the package and slide the first and last modules.
2. To complete the movement, depending on which side you are on, either press on the fold of the profiles with no visible hinges or press on the outer profile of the final module.

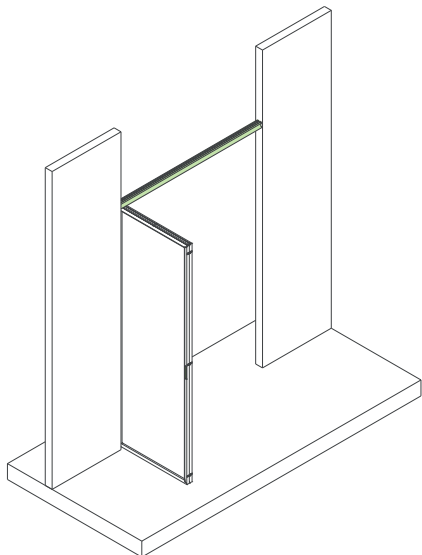

(b) Movement from lying wall to storage area

1. Stand facing the wall, depending on which side you are on, push on the center hinge or pull from the handle.
2. Partially folded the wall, stand frontally and push the wall toward the storage area until the modules touch each other.

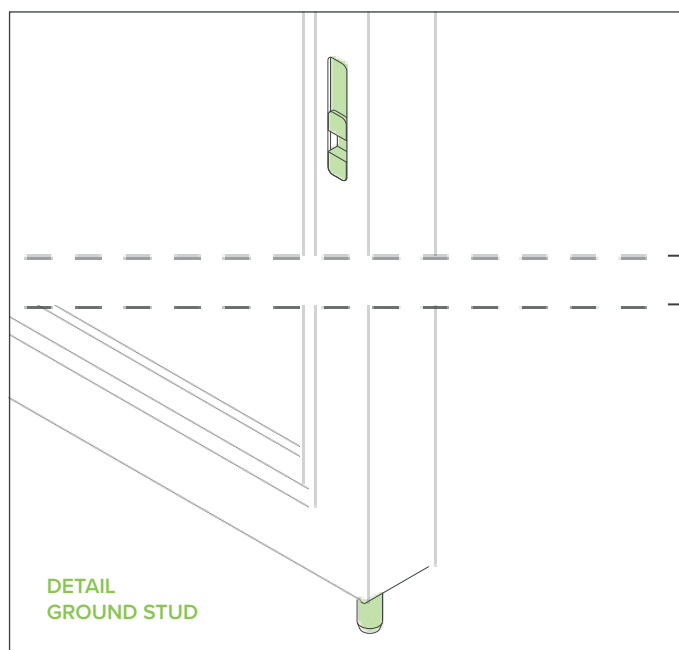
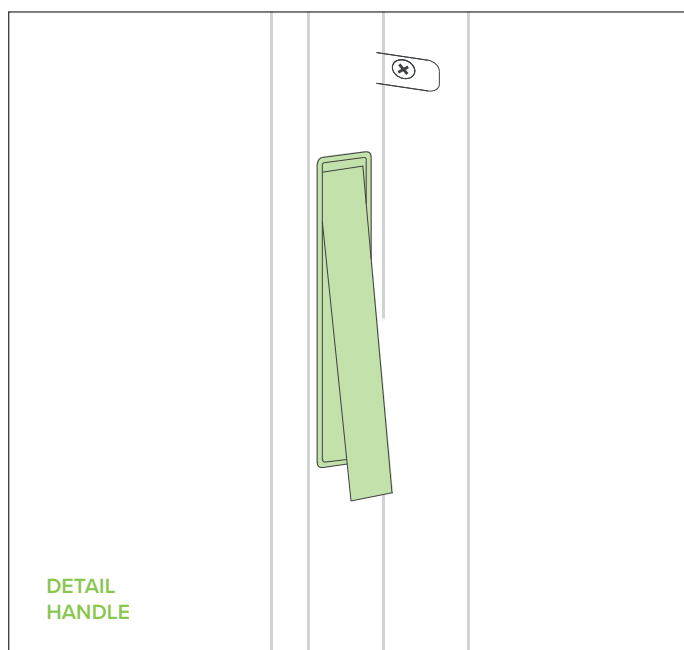
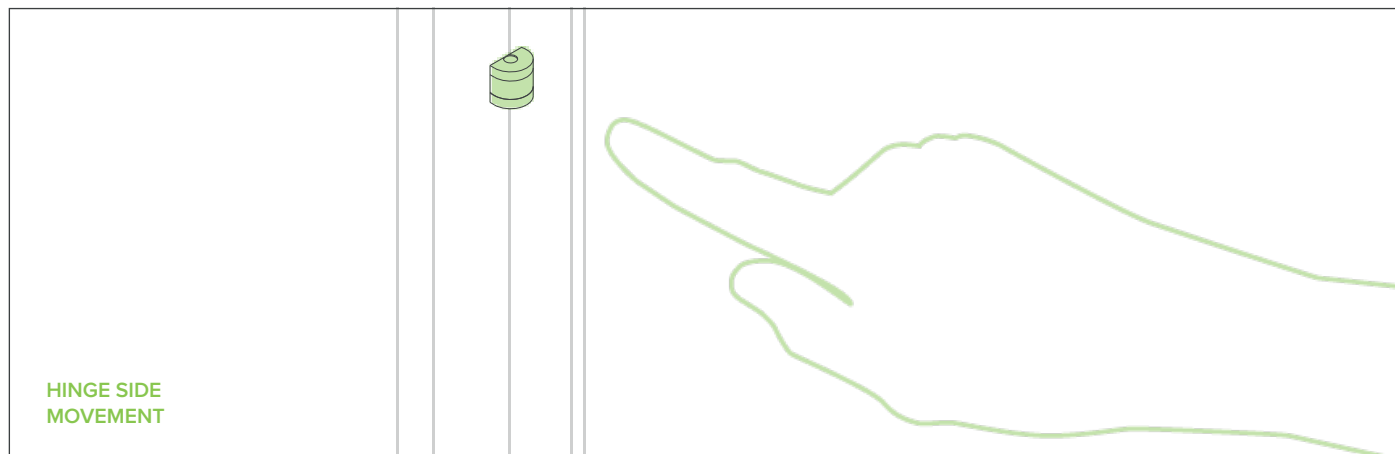
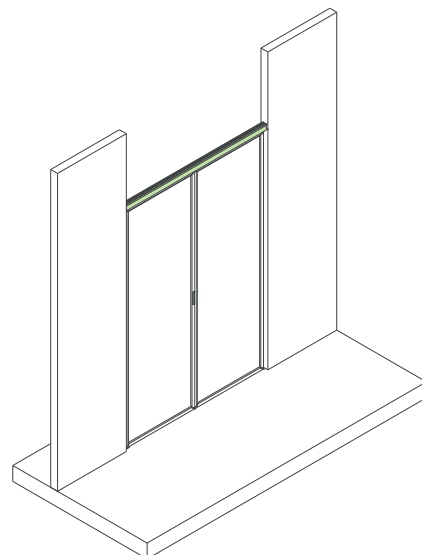
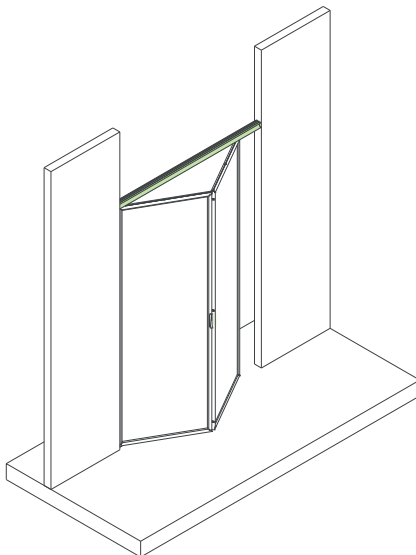

**INSTALLATION, USE AND MAINTENANCE MANUAL - AURA ZIP (off-axis)**

**EN**

This document is protected by copyright and intended exclusively for internal use. It is prohibited to make this document available to third parties, to reproduce it by any method or in any form - including extracts - and/or to utilise or communicate the content for any purpose other than internal use without the written consent of CARVART.

**CARVART®**

1441 Broadway floor 28,  
New York, NY 10018  
(212) 675-0030

[www.carvart.com](http://www.carvart.com)  
[info@carvart.com](mailto:info@carvart.com)

Follow us on

