

glassFOLDWALL > Framed

GW-FOLD-FD

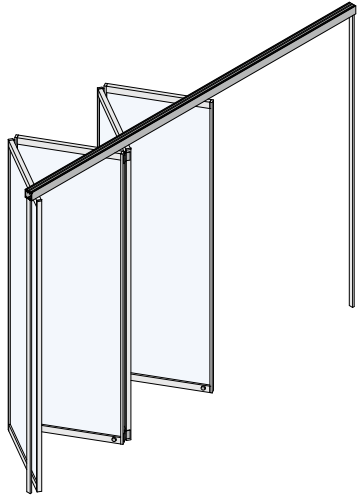

3D ISOMETRIC VIEW

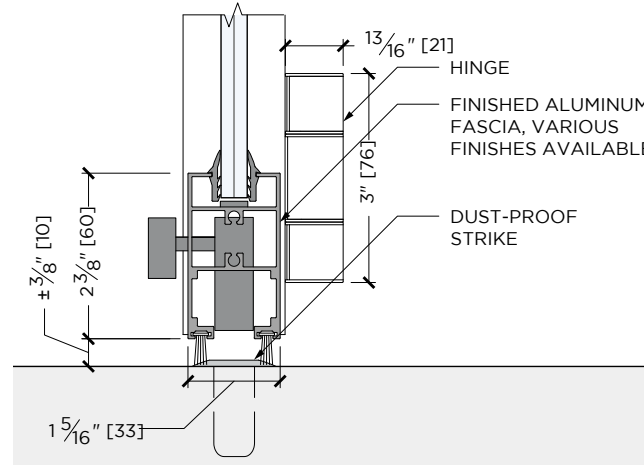

VERTICAL SECTION @ BASE SHOE



Specifications

glassFOLDWALL > Framed

Folding framed walls are easy-to-operate privacy options where glass panels are connected via hinges that move the entire series as they are pulled along the top track. Glass panels are fully-framed which provide the highest acoustical isolation. The track of top-hung system can be concealed in the ceiling. Vertical profiles are available at the walls to further improve acoustic isolation.

APPLICATIONS —

Space dividers, offices, commercial spaces, conference rooms

HARDWARE —

Anodized aluminum finishes; glass held by dry-glazed gaskets and verticals; top-hung panels that slide through track and hinged panels

HARDWARE FINISHES —

- MFSA (satin anodized aluminum)
- MFPA (polished anodized aluminum)
- MFBA (black anodized aluminum)
- MFBN (brushed antique nickel)
- MFBN (brushed satin nickel)

PANEL WIDTH (OVERALL MAXIMUM) —

Maximum: 37"

SYSTEM HEIGHT (OVERALL MAXIMUM) —

Maximum Height: 120"

MOUNTING OPTIONS —

- Top-hung; load-bearing header required
- Panels held by dry-glazed gaskets and verticals

GLASS THICKNESS —

Tempered monolithic and tempered laminated:
-3/8" [6mm] - 13/16" [21mm]

WARRANTY —

1 Year Limited Warranty

Specification Code: **GW-FOLD-FD**

GW	FOLD	FD
LINE	TYPE	MODEL/ID